



*An Online CPD Course
brought to you by
CEDengineering.ca*

Process Controls for Industrial Facility Systems

Course No: D05-001
Credit: 5 PDH

Gilbert Gedeon, P.E.



Continuing Education and Development, Inc.

P: (877) 322-5800
info@cedengineering.ca

This course was adapted from the Department of Energy, Publication No. DOE-HDBK-1013/2-92, “Instrumentation and Control”, Module 7, which is in the public domain.

TABLE OF CONTENTS

REFERENCES	iv
PRINCIPLES OF CONTROL SYSTEMS	1
Introduction	1
Terminology	2
Automatic Control System	4
Functions of Automatic Control	4
Elements of Automatic Control	4
Feedback Control	5
Summary	6
CONTROL LOOP DIAGRAMS	7
Terminology	7
Feedback Control System Block Diagram	9
Process Time Lags	13
Stability of Automatic Control Systems	13
Summary	16
TWO POSITION CONTROL SYSTEMS	17
Controllers	17
Two Position Controller	18
Example of Two Position Control	19
Modes of Automatic Control	19
Summary	21
PROPORTIONAL CONTROL SYSTEMS	22
Control Mode	22
Proportional Band	22
Example of a Proportional Process Control System	23
Summary	27

TABLE OF CONTENTS (Cont.)

RESET (INTEGRAL) CONTROL SYSTEMS	28
Reset Control (Integral)	28
Definition of Integral Control	28
Example of an Integral Flow Control System	29
Properties of Integral Control	32
Summary	32
PROPORTIONAL PLUS RESET CONTROL SYSTEMS	33
Proportional Plus Reset	33
Example of Proportional Plus Reset Control	34
Reset Windup	35
Summary	36
PROPORTIONAL PLUS RATE CONTROL SYSTEMS	37
Proportional-Derivative	37
Definition of Derivative Control	37
Example of Proportional Plus Rate Control	40
Applications	41
Summary	42
PROPORTIONAL-INTEGRAL-DERIVATIVE CONTROL SYSTEMS	43
Proportional-Integral-Derivative	43
Proportional Plus Reset Plus Rate Controller Actions	43
Summary	46
CONTROLLERS	47
Controllers	47
Control Stations	47
Self-Balancing Control Stations	50
Summary	53

TABLE OF CONTENTS (Cont.)

VALVE ACTUATORS	54
Actuators	54
Pneumatic Actuators	54
Hydraulic Actuators	57
Electric Solenoid Actuators	58
Electric Motor Actuators	59
Summary	60

REFERENCES

- Anderson, N.A., Instrumentation for Process Measurement and Control, Second Edition, Chilton Company, Philadelphia, PA, 1972.
- Considine, D.M., Process Instruments and Controls Handbook, Second Edition, McGraw-Hill Book Company, Inc., New York, NY, 1974.
- Distefano, J.J. III, Feedback and Control Systems, Schaum's Outline Series, 1967.
- Kirk, Franklin W. and Rimboi, Nicholas R., Instrumentation, Third Edition, American Technical Publishers, ISBN 0-8269-3422-6.
- Academic Program for Nuclear Power Plant Personnel, Volume IV, General Physics Corporation, Library of Congress Card #A 397747, April 1982.
- Fozard, B., Instrumentation and Control of Nuclear Reactors, ILIFFE Books Ltd., London.
- Wightman, E.J., Instrumentation in Process Control, CRC Press, Cleveland, Ohio.
- Rhodes, T.J. and Carroll, G.C., Industrial Instruments for Measurement and Control, Second Edition, McGraw-Hill Book Company.
- Process Measurement Fundamentals, Volume I, General Physics Corporation, ISBN 0-87683-001-7, 1981.

PRINCIPLES OF CONTROL SYSTEMS

Control systems integrate elements whose function is to maintain a process variable at a desired value or within a desired range of values.

- EO 1.1 DEFINE the following process control terms:**
- a. Control system**
 - b. Control system input**
 - c. Control system output**
 - d. Open-loop system**
 - e. Closed-loop system**
 - f. Feedback**
 - g. Controlled variable**
 - h. Manipulated variable**
-

Introduction

Instrumentation provides the various indications used to operate a nuclear facility. In some cases, operators record these indications for use in day-to-day operation of the facility. The information recorded helps the operator evaluate the current condition of the system and take actions if the conditions are not as expected.

Requiring the operator to take all of the required corrective actions is impractical, or sometimes impossible, especially if a large number of indications must be monitored. For this reason, most systems are controlled automatically once they are operating under normal conditions. Automatic controls greatly reduce the burden on the operator and make his or her job manageable.

Process variables requiring control in a system include, but are not limited to, flow, level, temperature, and pressure. Some systems do not require all of their process variables to be controlled. Think of a central heating system. A basic heating system operates on temperature and disregards the other atmospheric parameters of the house. The thermostat monitors the temperature of the house. When the temperature drops to the value selected by the occupants of the house, the system activates to raise the temperature of the house. When the temperature reaches the desired value, the system turns off.

Automatic control systems neither replace nor relieve the operator of the responsibility for maintaining the facility. The operation of the control systems is periodically checked to verify proper operation. If a control system fails, the operator must be able to take over and control the process manually. In most cases, understanding how the control system works aids the operator in determining if the system is operating properly and which actions are required to maintain the system in a safe condition.

Terminology

A **control system** is a system of integrated elements whose function is to maintain a process variable at a desired value or within a desired range of values. The control system monitors a process variable or variables, then causes some action to occur to maintain the desired system parameter. In the example of the central heating unit, the system monitors the temperature of the house using a thermostat. When the temperature of the house drops to a preset value, the furnace turns on, providing a heat source. The temperature of the house increases until a switch in the thermostat causes the furnace to turn off.

Two terms which help define a control system are input and output. **Control system input** is the stimulus applied to a control system from an external source to produce a specified response from the control system. In the case of the central heating unit, the control system input is the temperature of the house as monitored by the thermostat.

Control system output is the actual response obtained from a control system. In the example above, the temperature dropping to a preset value on the thermostat causes the furnace to turn on, providing heat to raise the temperature of the house.

In the case of nuclear facilities, the input and output are defined by the purpose of the control system. A knowledge of the input and output of the control system enables the components of the system to be identified. A control system may have more than one input or output.

Control systems are classified by the control action, which is the quantity responsible for activating the control system to produce the output. The two general classifications are open-loop and closed-loop control systems.

An **open-loop control system** is one in which the control action is independent of the output. An example of an open-loop control system is a chemical addition pump with a variable speed control (Figure 1). The feed rate of chemicals that maintain proper chemistry of a system is determined by an operator, who is not part of the control system. If the chemistry of the system changes, the pump cannot respond by adjusting its feed rate (speed) without operator action.

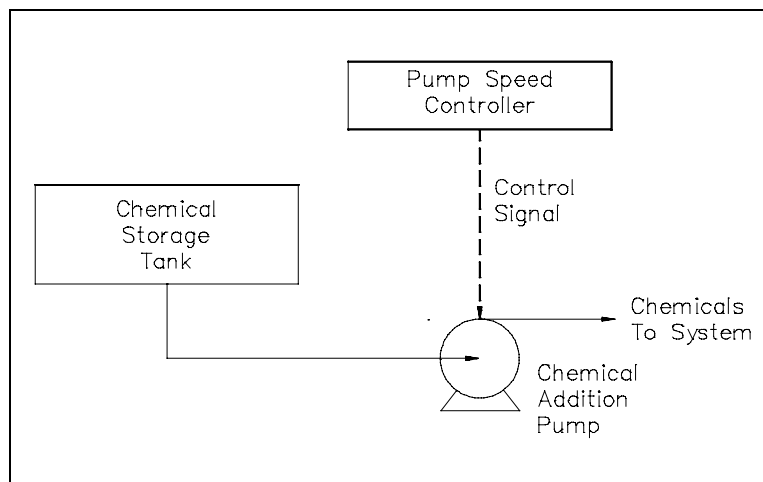

Figure 1 Open-Loop Control System

A **closed-loop control system** is one in which control action is dependent on the output. Figure 2 shows an example of a closed-loop control system. The control system maintains water level in a storage tank. The system performs this task by continuously sensing the level in the tank and adjusting a supply valve to add more or less water to the tank. The desired level is preset by an operator, who is not part of the system.

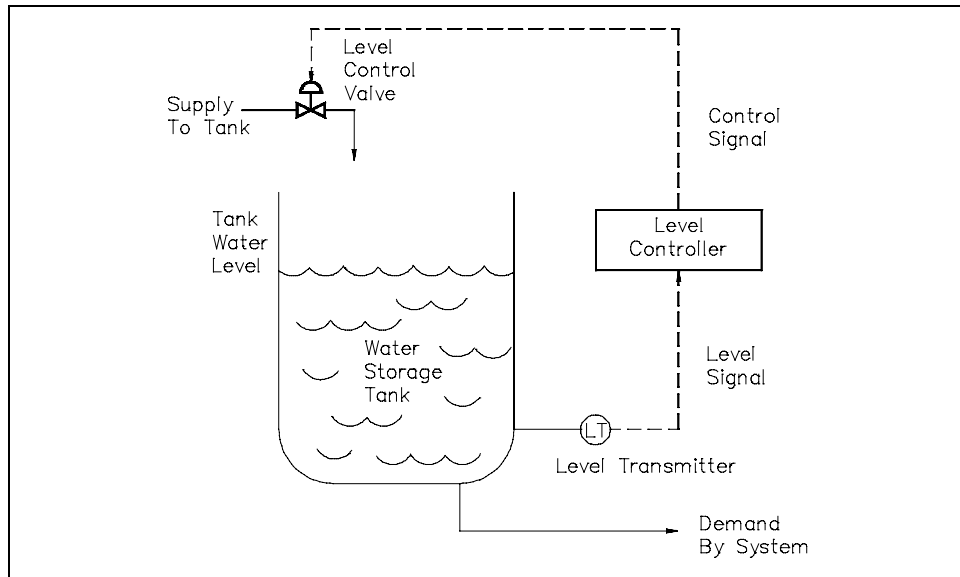

Figure 2 Closed-Loop Control System

Feedback is information in a closed-loop control system about the condition of a process variable. This variable is compared with a desired condition to produce the proper control action on the process. Information is continually "fed back" to the control circuit in response to control action. In the previous example, the actual storage tank water level, sensed by the level transmitter, is feedback to the level controller. This feedback is compared with a desired level to produce the required control action that will position the level control as needed to maintain the desired level. Figure 3 shows this relationship.

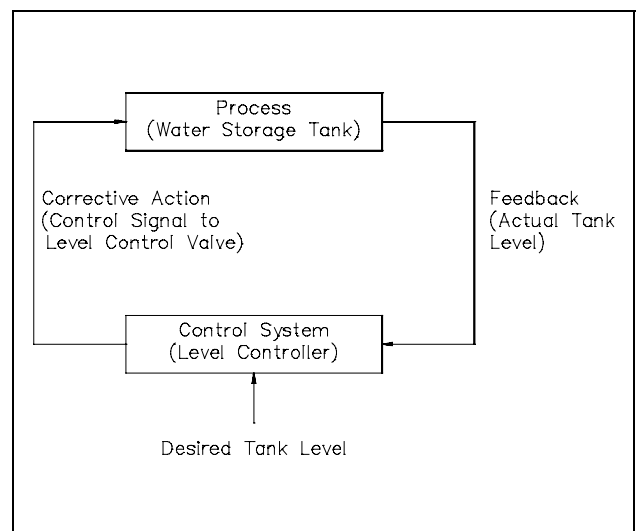

Figure 3 Feedback in a Closed-Loop Control System

Automatic Control System

An automatic control system is a preset closed-loop control system that requires no operator action. This assumes the process remains in the normal range for the control system. An automatic control system has two process variables associated with it: a controlled variable and a manipulated variable.

A *controlled variable* is the process variable that is maintained at a specified value or within a specified range. In the previous example, the storage tank level is the controlled variable.

A *manipulated variable* is the process variable that is acted on by the control system to maintain the controlled variable at the specified value or within the specified range. In the previous example, the flow rate of the water supplied to the tank is the manipulated variable.

Functions of Automatic Control

In any automatic control system, the four basic functions that occur are:

- Measurement
- Comparison
- Computation
- Correction

In the water tank level control system in the example above, the level transmitter measures the level within the tank. The level transmitter sends a signal representing the tank level to the level control device, where it is compared to a desired tank level. The level control device then computes how far to open the supply valve to correct any difference between actual and desired tank levels.

Elements of Automatic Control

The three functional elements needed to perform the functions of an automatic control system are:

- A measurement element
- An error detection element
- A final control element

Relationships between these elements and the functions they perform in an automatic control system are shown in Figure 4. The measuring element performs the measuring function by sensing and evaluating the controlled variable. The error detection element first compares the value of the controlled variable to the desired value, and then signals an error if a deviation exists between the actual and desired values. The final control element responds to the error signal by correcting the manipulated variable of the process.

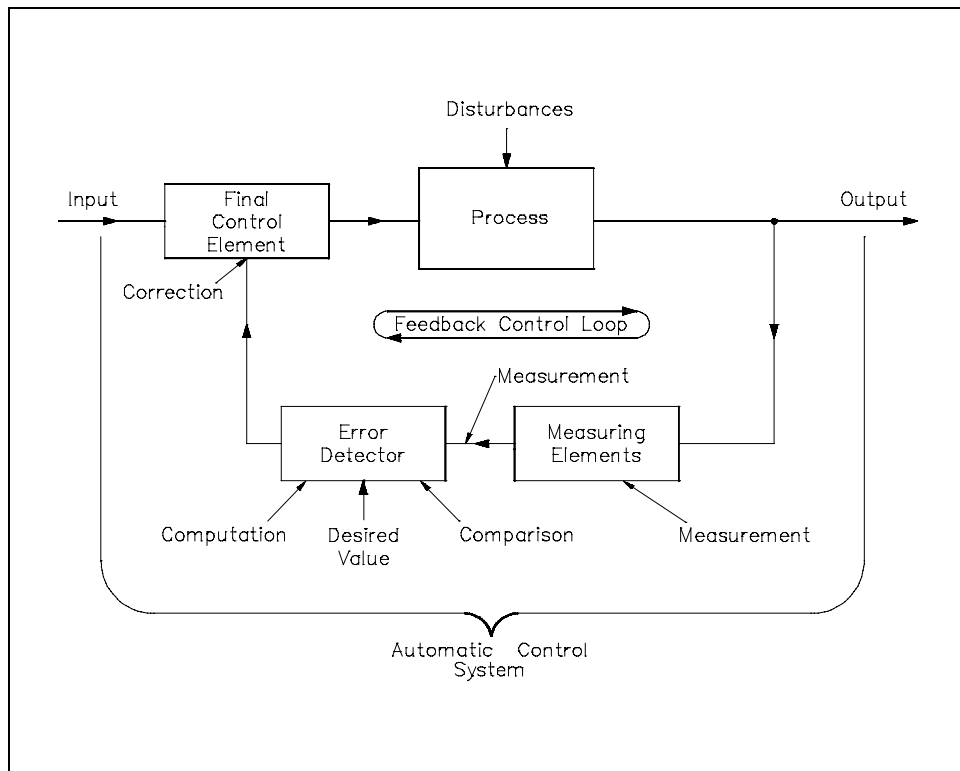

Figure 4 Relationships of Functions and Elements in an Automatic Control System

Feedback Control

An automatic controller is an error-sensitive, self-correcting device. It takes a signal from the process and feeds it back into the process. Therefore, closed-loop control is referred to as feedback control.

Summary

Basic process control terms are summarized below.

Process Control Term Definitions Summary

- A *control system* is a system of integrated elements whose function is to maintain a process variable at a desired value or within a desired range of values.
- *Control system input* is the stimulus applied to a control system from an external source to produce a specified response from the control system.
- *Control system output* is the actual response obtained from a control system.
- An *open-loop control system* is one in which the control action is independent of the output.
- A *closed-loop control system* is one in which control action is dependent on the output.
- *Feedback* is information in a closed-loop control system about the condition of a process variable.
- A *controlled variable* is the process variable that is maintained at a specified value or within a specified range.
- A *manipulated variable* is the process variable that is acted on by the control system to maintain the controlled variable at the specified value or within the specified range.

CONTROL LOOP DIAGRAMS

A loop diagram is a "roadmap" that traces process fluids through the system and designates variables that can disrupt the balance of the system.

- EO 1.2** **DESCRIBE** the operation of a control loop diagram including the following components:
- a. **Controlled system**
 - b. **Controlled elements**
 - c. **Feedback elements**
 - d. **Reference point**
 - e. **Controlled output**
 - f. **Feedback signal**
 - g. **Actuating signal**
 - h. **Manipulated variable**
 - i. **Disturbance**

- EO 1.3** **EXPLAIN** how capacitance, resistance, and transportation time affect a control system's lag time.
-

Terminology

A *block diagram* is a pictorial representation of the cause and effect relationship between the input and output of a physical system. A block diagram provides a means to easily identify the functional relationships among the various components of a control system.

The simplest form of a block diagram is the *block and arrows diagram*. It consists of a single block with one input and one output (Figure 5A). The block normally contains the name of the element (Figure 5B) or the symbol of a mathematical operation (Figure 5C) to be performed on the input to obtain the desired output. Arrows identify the direction of information or signal flow.

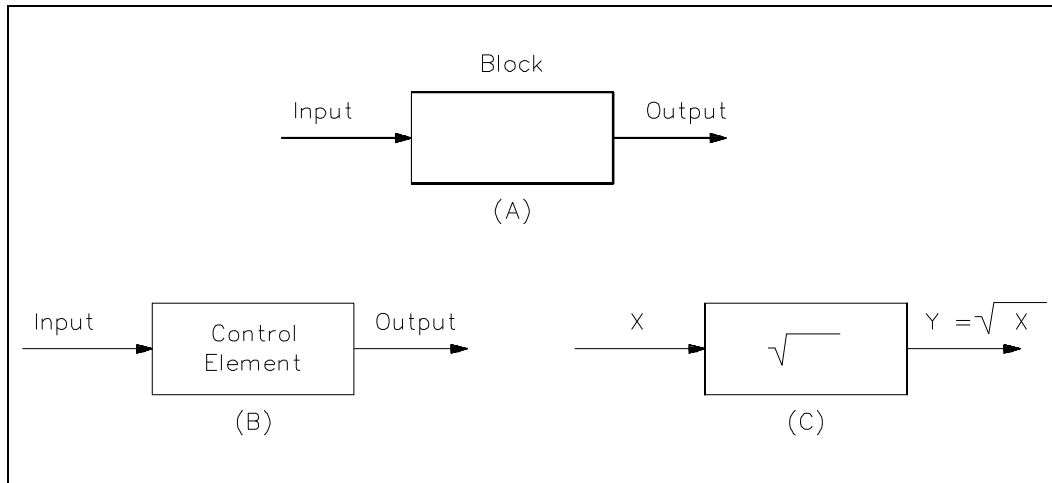

Figure 5 Block and Arrows

Although blocks are used to identify many types of mathematical operations, operations of addition and subtraction are represented by a circle, called a *summing point*. As shown in Figure 6, a summing point may have one or several inputs. Each input has its own appropriate plus or minus sign. A summing point has only one output and is equal to the algebraic sum of the inputs.

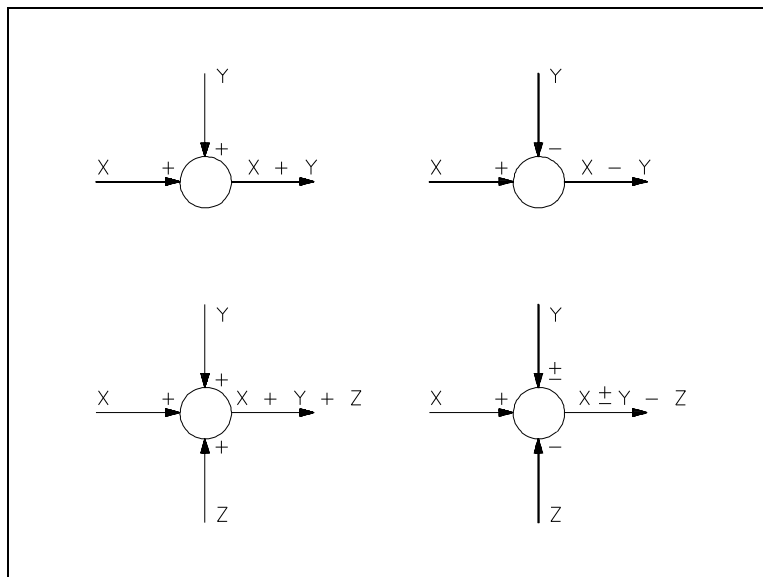

Figure 6 Summing Points

A *takeoff point* is used to allow a signal to be used by more than one block or summing point (Figure 7).

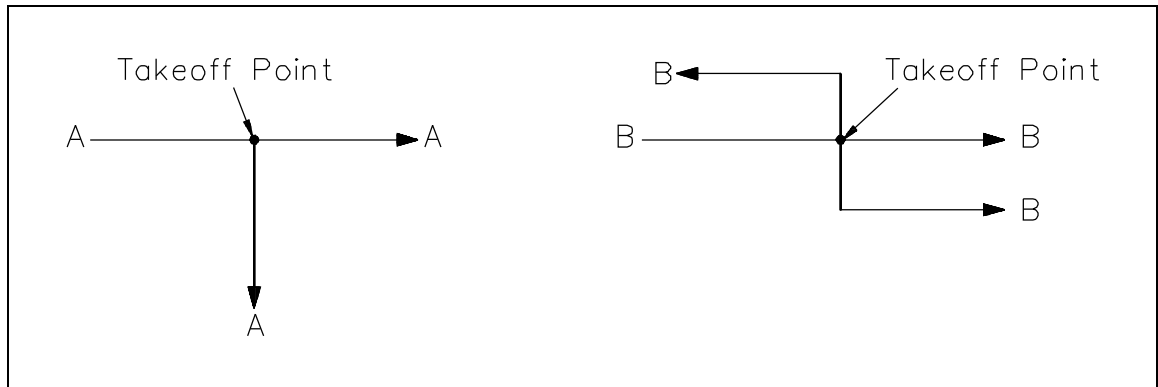

Figure 7 Takeoff Point

Feedback Control System Block Diagram

Figure 8 shows basic elements of a feedback control system as represented by a block diagram. The functional relationships between these elements are easily seen. An important factor to remember is that the block diagram represents flowpaths of control signals, but does not represent flow of energy through the system or process.

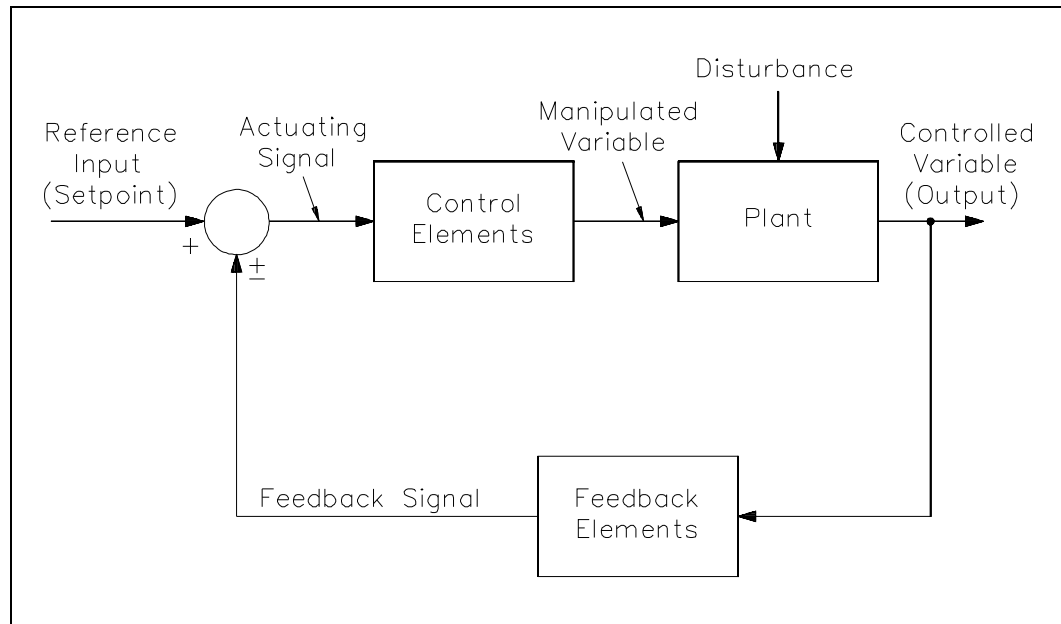

Figure 8 Feedback Control System Block Diagram

Below are several terms associated with the closed-loop block diagram.

The plant is the system or process through which a particular quantity or condition is controlled. This is also called the *controlled system*.

The *control elements* are components needed to generate the appropriate control signal applied to the plant. These elements are also called the "controller."

The *feedback elements* are components needed to identify the functional relationship between the feedback signal and the controlled output.

The *reference point* is an external signal applied to the summing point of the control system to cause the plant to produce a specified action. This signal represents the desired value of a controlled variable and is also called the "setpoint."

The *controlled output* is the quantity or condition of the plant which is controlled. This signal represents the controlled variable.

The *feedback signal* is a function of the output signal. It is sent to the summing point and algebraically added to the reference input signal to obtain the actuating signal.

The *actuating signal* represents the control action of the control loop and is equal to the algebraic sum of the reference input signal and feedback signal. This is also called the "error signal."

The *manipulated variable* is the variable of the process acted upon to maintain the plant output (controlled variable) at the desired value.

The *disturbance* is an undesirable input signal that upsets the value of the controlled output of the plant.

Figure 9 shows a typical application of a block diagram to identify the operation of a temperature control system for lubricating oil. (A) in Figure 9 shows a schematic diagram of the lube oil cooler and its associated temperature control system.

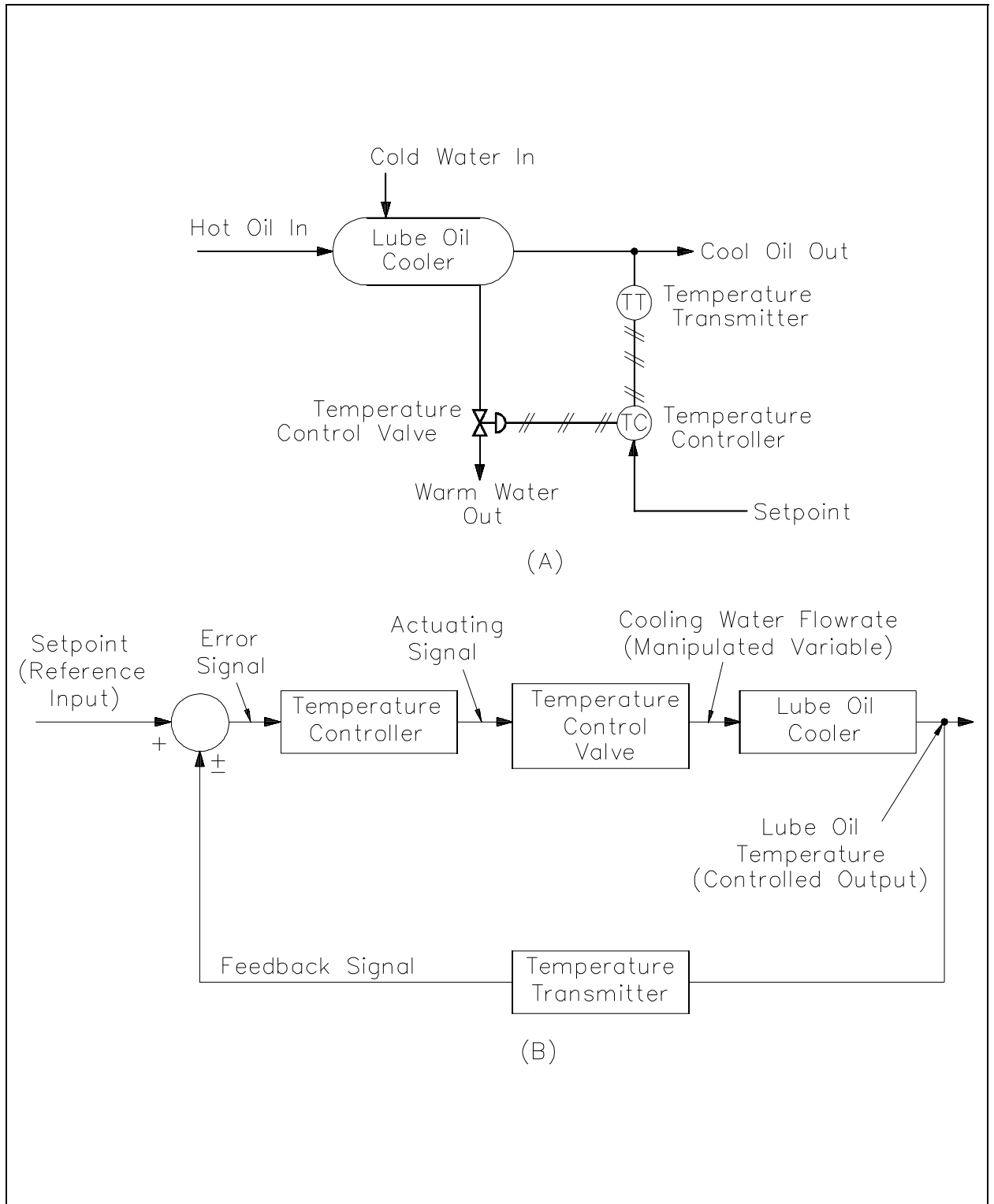

Figure 9 Lube Oil Cooler Temperature Control System and Equivalent Block Diagram

Lubricating oil reduces friction between moving mechanical parts and also removes heat from the components. As a result, the oil becomes hot. This heat is removed from the lube oil by a cooler to prevent both breakdown of the oil and damage to the mechanical components it serves.

The lube oil cooler consists of a hollow shell with several tubes running through it. Cooling water flows inside the shell of the cooler and around the outside of the tubes. Lube oil flows inside the tubes. The water and lube oil never make physical contact.

As the water flows through the shell side of the cooler, it picks up heat from the lube oil through the tubes. This cools the lube oil and warms the cooling water as it leaves the cooler.

The lube oil must be maintained within a specific operating band to ensure optimum equipment performance. This is accomplished by controlling the flow rate of the cooling water with a *temperature control loop*.

The temperature control loop consists of a temperature transmitter, a temperature controller, and a temperature control valve. The diagonally crossed lines indicate that the control signals are air (pneumatic).

The lube oil temperature is the controlled variable because it is maintained at a desired value (the setpoint). Cooling water flow rate is the manipulated variable because it is adjusted by the temperature control valve to maintain the lube oil temperature. The temperature transmitter senses the temperature of the lube oil as it leaves the cooler and sends an air signal that is proportional to the temperature controller. Next, the temperature controller compares the actual temperature of the lube oil to the setpoint (the desired value). If a difference exists between the actual and desired temperatures, the controller will vary the control air signal to the temperature control valve. This causes it to move in the direction and by the amount needed to correct the difference. For example, if the actual temperature is greater than the setpoint value, the controller will vary the control air signal and cause the valve to move in the open direction.

This results in more cooling water flowing through the cooler and lowers the temperature of the lube oil leaving the cooler.

(B) in Figure 9 represents the lube oil temperature control loop in block diagram form. The lube oil cooler is the plant in this example, and its controlled output is the lube oil temperature. The temperature transmitter is the feedback element. It senses the controlled output and lube oil temperature and produces the feedback signal.

The feedback signal is sent to the summing point to be algebraically added to the reference input (the setpoint). Notice the setpoint signal is positive, and the feedback signal is negative. This means the resulting actuating signal is the difference between the setpoint and feedback signals.

The actuating signal passes through the two control elements: the temperature controller and the temperature control valve. The temperature control valve responds by adjusting the manipulated variable (the cooling water flow rate). The lube oil temperature changes in response to the different water flow rate, and the control loop is complete.

Process Time Lags

In the last example, the control of the lube oil temperature may initially seem easy. Apparently, the operator need only measure the lube oil temperature, compare the actual temperature to the desired (setpoint), compute the amount of error (if any), and adjust the temperature control valve to correct the error accordingly. However, processes have the characteristic of delaying and retarding changes in the values of the process variables. This characteristic greatly increases the difficulty of control.

Process time lags is the general term that describes these process delays and retardations.

Process time lags are caused by three properties of the process. They are: *capacitance*, *resistance*, and *transportation time*.

Capacitance is the ability of a process to store energy. In Figure 9, for example, the walls of the tubes in the lube oil cooler, the cooling water, and the lube oil can store heat energy. This energy-storing property gives the ability to retard change. If the cooling water flow rate is increased, it will take a period of time for more energy to be removed from the lube oil to reduce its temperature.

Resistance is that part of the process that opposes the transfer of energy between capacities. In Figure 9, the walls of the lube oil cooler oppose the transfer of heat from the lube oil inside the tubes to the cooling water outside the tubes.

Transportation time is time required to carry a change in a process variable from one point to another in the process. If the temperature of the lube oil (Figure 9) is lowered by increasing the cooling water flow rate, some time will elapse before the lube oil travels from the lube oil cooler to the temperature transmitter. If the transmitter is moved farther from the lube oil cooler, the transportation time will increase. This time lag is not just a slowing down or retardation of a change; it is an actual time delay during which no change occurs.

Stability of Automatic Control Systems

All control modes previously described can return a process variable to a steady value following a disturbance. This characteristic is called "stability."

Stability is the ability of a control loop to return a controlled variable to a steady, non-cyclic value, following a disturbance.

Control loops can be either stable or unstable. Instability is caused by a combination of process time lags discussed earlier (i.e., capacitance, resistance, and transport time) and inherent time lags within a control system. This results in slow response to changes in the controlled variable. Consequently, the controlled variable will continuously cycle around the setpoint value.

Oscillations describes this cyclic characteristic. There are three types of oscillations that can occur in a control loop. They are *decreasing amplitude*, *constant amplitude*, and *increasing amplitude*. Each is shown in Figure 10.

Decreasing amplitude (Figure 10A). These oscillations decrease in amplitude and eventually stop with a control system that opposes the change in the controlled variable. This is the condition desired in an automatic control system.

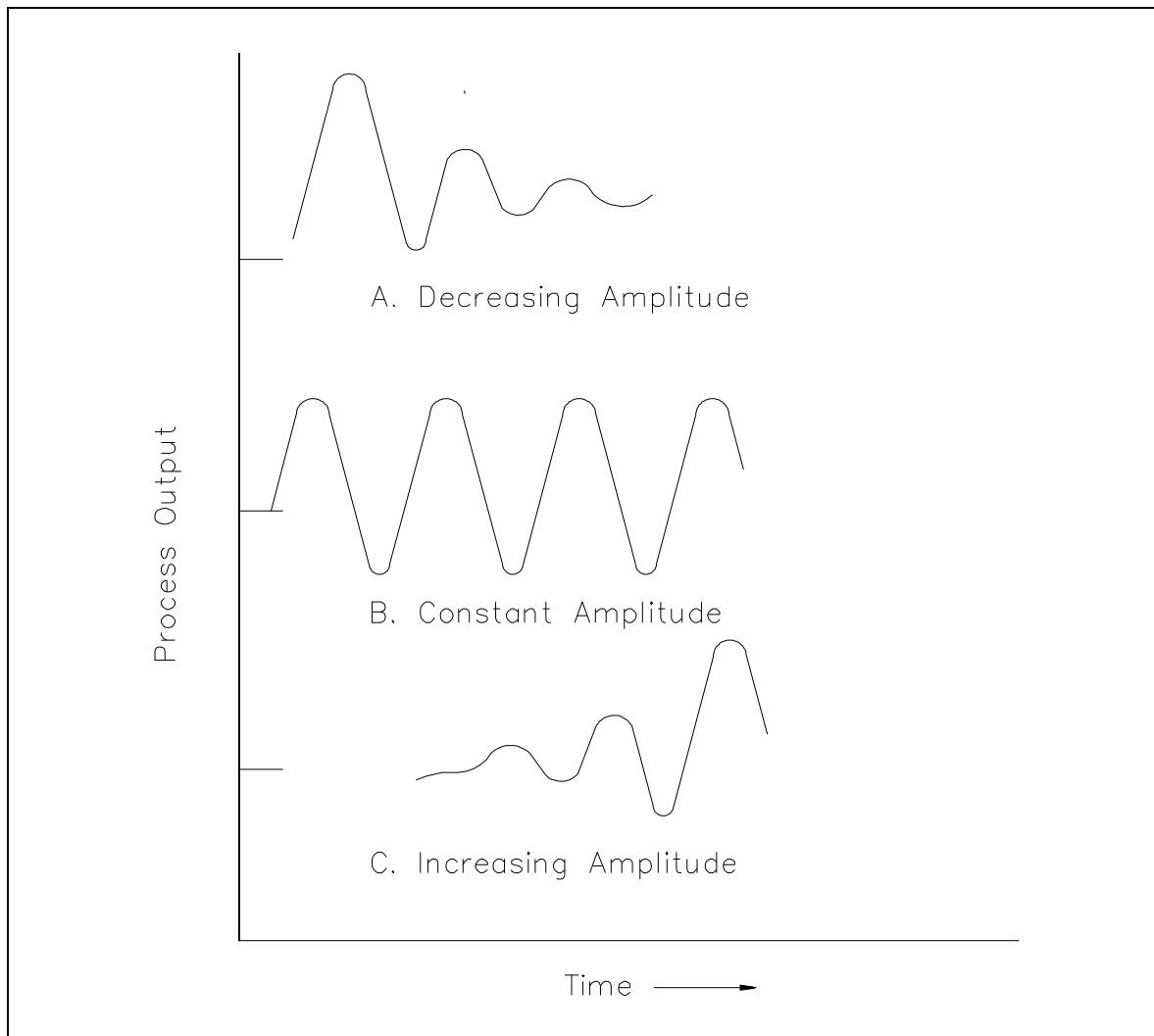

Figure 10 Types of Oscillations

Constant amplitude (Figure 10B). Action of the controller sustains oscillations of the controlled variable. The controlled variable will never reach a stable condition; therefore, this condition is not desired.

Increasing amplitude (Figure 10C). The control system not only sustains oscillations but also increases them. The control element has reached its full travel limits and causes the process to go out of control.

Summary

The important information in this chapter is summarized below.

Control Loop Diagrams Summary

- A controlled system is the system or process through which a particular quantity or condition is controlled.
- Control elements are components needed to generate the appropriate control signal applied to the plant. These elements are also called the "controller."
- Feedback elements are components needed to identify the functional relationship between the feedback signal and the controlled output.
- Reference point is an external signal applied to the summing point of the control system to cause the plant to produce a specified action.
- Controlled output is the quantity or condition of the plant which is controlled. This signal represents the controlled variable.
- Feedback signal is a function of the output signal. It is sent to the summing point and algebraically added to the reference input signal to obtain the actuating signal.
- The actuating signal represents the control action of the control loop and is equal to the algebraic sum of the reference input signal and feedback signal. This is also called the "error signal."
- The manipulated variable is the variable of the process acted upon to maintain the plant output (controlled variable) at the desired value.
- A disturbance is an undesirable input signal that upsets the value of the controlled output of the plant.
- Process time lags are affected by capacitance, which is the ability of a process to store energy; resistance, the part of the process that opposes the transfer of energy between capacities; and transportation time, the time required to carry a change in a process variable from one point to another in the process. This time lag is not just a slowing down of a change, but rather the actual time delay during which no change occurs.

TWO POSITION CONTROL SYSTEMS

A two position controller is the simplest type of controller.

- EO 1.4** **DESCRIBE** the characteristics of the following types of automatic control systems:
- a. **Two position control system**

Controllers

A controller is a device that generates an output signal based on the input signal it receives. The input signal is actually an error signal, which is the difference between the measured variable and the desired value, or setpoint.

This input error signal represents the amount of deviation between where the process system is actually operating and where the process system is desired to be operating. The controller provides an output signal to the final control element, which adjusts the process system to reduce this deviation. The characteristic of this output signal is dependent on the type, or mode, of the controller. This chapter describes the simplest type of controller, which is the two position, or ON-OFF, mode controller.

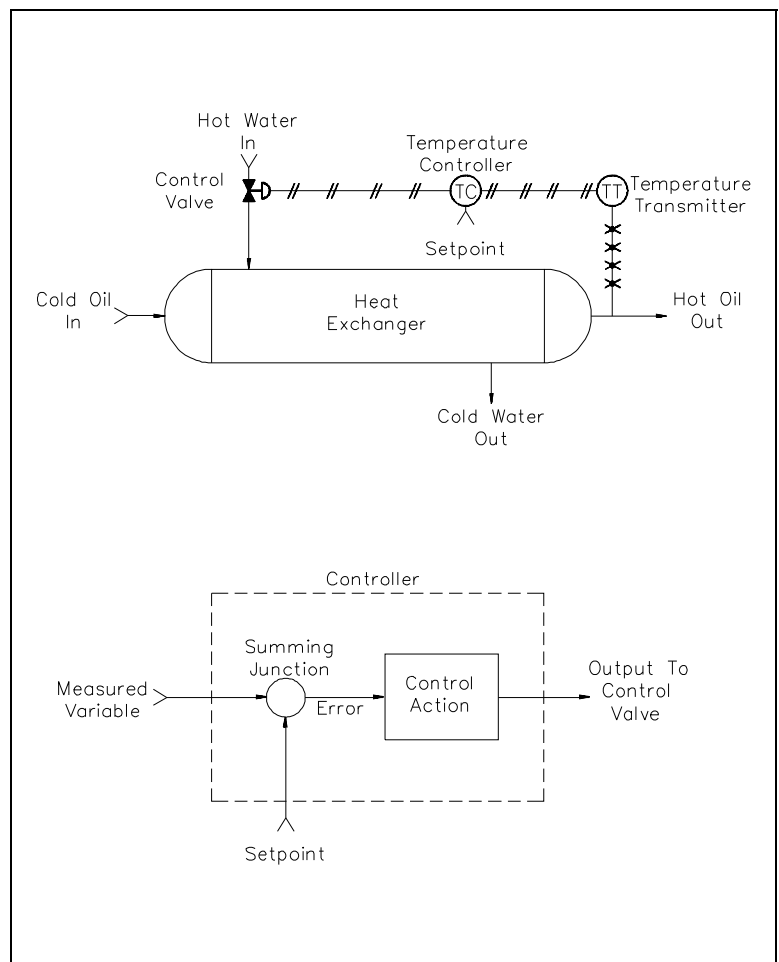

Figure 11 Process Control System Operation

Two Position Controller

A two position controller is a device that has two operating conditions: completely on or completely off.

Figure 12 shows the input to output, characteristic waveform for a two position controller that switches from its "OFF" state to its "ON" state when the measured variable increases above the setpoint. Conversely, it switches from its "ON" state to its "OFF" state when the measured variable decreases below the setpoint. This device provides an output determined by whether the error signal is above or below the setpoint. The magnitude of the error signal is above or below the setpoint. The magnitude of the error signal past that point is of no concern to the controller.

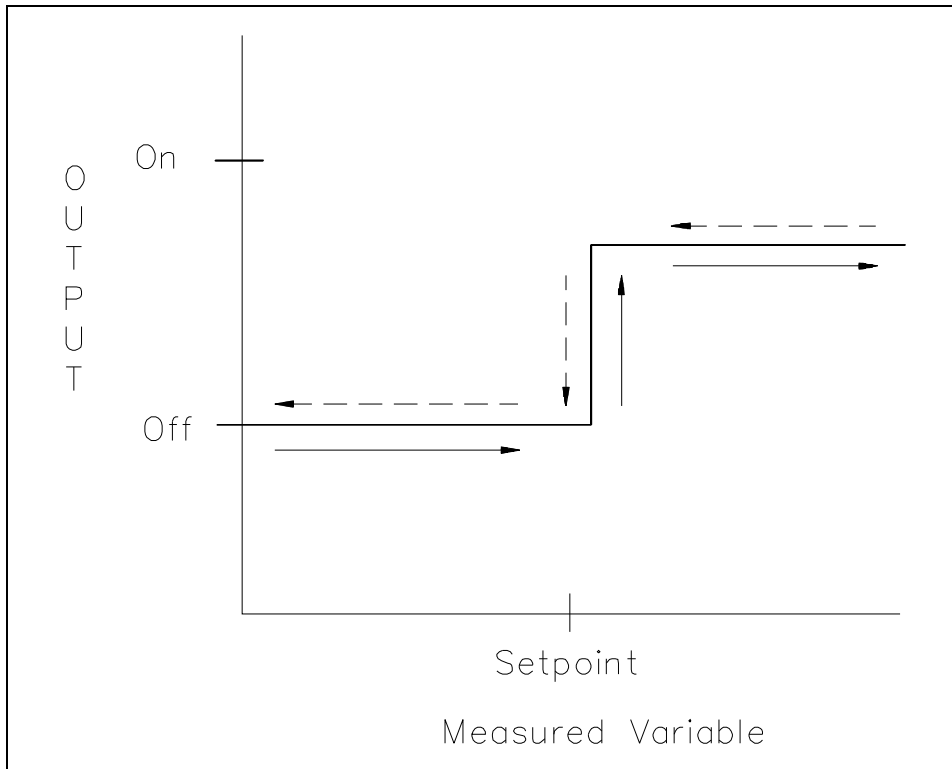

Figure 12 Two Position Controller Input/Output Relationship

Example of Two Position Control

A system using a two position controller is shown in Figure 13.

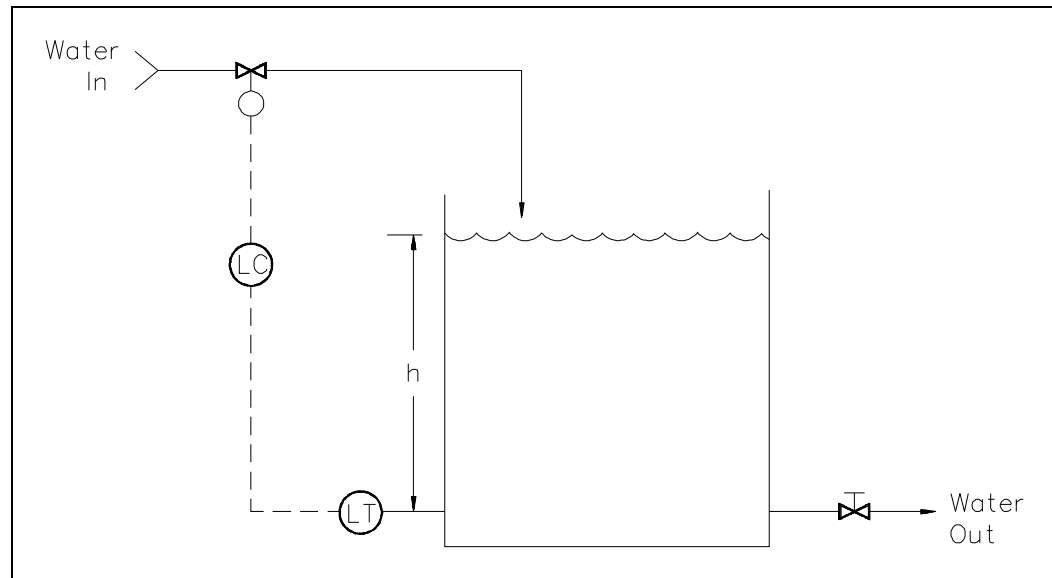

Figure 13 Two Position Control System

The controlled process is the volume of water in the tank. The controlled variable is the level in the tank. It is measured by a level detector that sends information to the controller. The output of the controller is sent to the final control element, which is a solenoid valve, that controls the flow of water into the tank.

As the water level decreases initially, a point is reached where the measured variable drops below the setpoint. This creates a positive error signal. The controller opens the final control element fully. Water is subsequently injected into the tank, and the water level rises. As soon as the water level rises above the setpoint, a negative error signal is developed. The negative error signal causes the controller to shut the final control element. This opening and closing of the final control element results in a cycling characteristic of the measured variable.

Modes of Automatic Control

The mode of control is the manner in which a control system makes corrections relative to an error that exists between the desired value (setpoint) of a controlled variable and its actual value. The mode of control used for a specific application depends on the characteristics of the process being controlled. For example, some processes can be operated over a wide band, while others must be maintained very close to the setpoint. Also, some processes change relatively slowly, while others change almost immediately.

Deviation is the difference between the setpoint of a process variable and its actual value. This is a key term used when discussing various modes of control.

Four modes of control commonly used for most applications are:

- proportional
- proportional plus reset (PI)
- proportional plus rate (PD)
- proportional plus reset plus rate (PID)

Each mode of control has characteristic advantages and limitations. The modes of control are discussed in this and the next several sections of this module.

In the *proportional (throttling) mode*, there is a continuous linear relation between value of the controlled variable and position of the final control element. In other words, amount of valve movement is proportional to amount of deviation.

Figure 14 shows the relationship between valve position and controlled variable (temperature) characteristics of proportional mode. Notice that valve position changes in exact proportion to deviation. Also, the proportional mode responds only to amount of deviation and is insensitive to rate or duration of deviation. At the 2 minute and 4 minute marks, when the temperature returns to its setpoint value, the valve returns to its initial position. There is no valve correction without deviation.

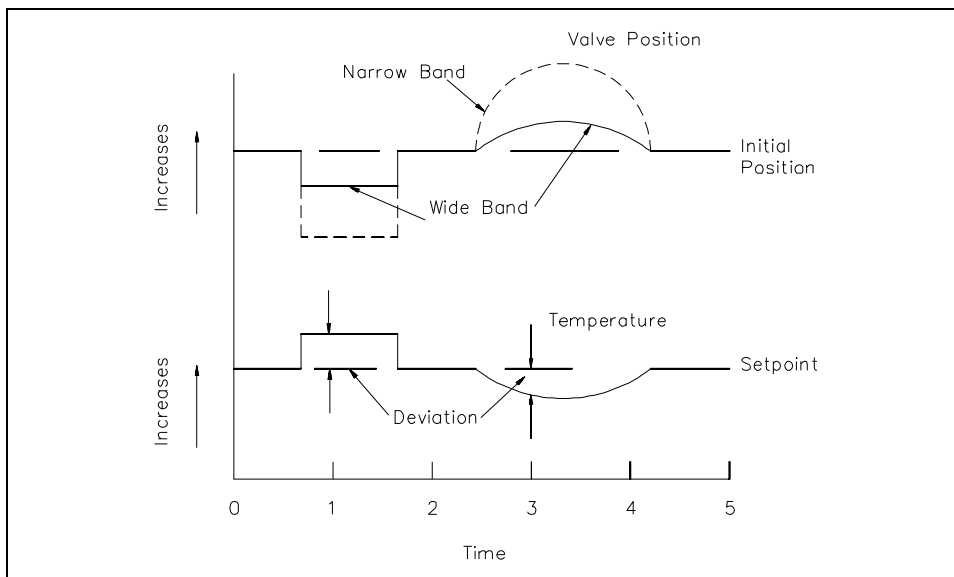

Figure 14 Relation Between Valve Position and Controlled Variable Under Proportional Mode

Three terms commonly used to describe the proportional mode of control are *proportional band*, *gain*, and *offset*.

Proportional band, (also called *throttling range*), is the change in value of the controlled variable that causes full travel of the final control element. Figure 14 shows the relationship between valve position and temperature band for two different proportional bands.

The proportional band of a particular instrument is expressed as a percent of full range. For example, if full range of an instrument is 200°F and it takes a 50°F change in temperature to cause full valve travel, the percent proportional band is 50°F in 200°F, or 25%. Proportional bands may range from less than 1% to well over 200%. However, proportional bands over 100% cannot cause full valve travel even for full range change of the controlled variable.

Gain, also called *sensitivity*, compares the ratio of amount of change in the final control element to amount of change in the controlled variable. Mathematically, gain and sensitivity are reciprocal to proportional band.

Offset, also called *droop*, is deviation that remains after a process has stabilized. Offset is an inherent characteristic of the proportional mode of control. In other words, the proportional mode of control will not necessarily return a controlled variable to its setpoint.

Summary

The important information in this chapter is summarized below:

Two Position Controller Summary

- It is a device that has two operating conditions: completely on or completely off.
- This device provides an output determined by whether the error signal is above or below the setpoint.
- *Deviation* is the difference between the setpoint of a process variable and its actual value.
- In the proportional (throttling) mode, the amount of valve movement is proportional to the amount of deviation. *Gain* compares the ratio of amount of change in the final control element to change in the controlled variable, and *offset* is the deviation that remains after a process has been stabilized.

PROPORTIONAL CONTROL SYSTEMS

Proportional control is also referred to as throttling control.

EO 1.4 DESCRIBE the characteristics of the following types of automatic control systems:

b. Proportional control system

Control Mode

In the proportional control mode, the final control element is throttled to various positions that are dependent on the process system conditions. For example, a proportional controller provides a linear stepless output that can position a valve at intermediate positions, as well as "full open" or "full shut." The controller operates within a band that is between the 0% output point and the 100% output point and where the output of the controller is proportional to the input signal.

Proportional Band

With proportional control, the final control element has a definite position for each value of the measured variable. In other words, the output has a linear relationship with the input. Proportional band is the change in input required to produce a full range of change in the output due to the proportional control action. Or simply, it is the percent change of the input signal required to change the output signal from 0% to 100%.

The proportional band determines the range of output values from the controller that operate the final control element. The final control element acts on the manipulated variable to determine the value of the controlled variable. The controlled variable is maintained within a specified band of control points around a setpoint.

To demonstrate, let's look at Figure 15.

In this example of a proportional level control system, the flow of supply water into the tank is controlled to maintain the tank water level within prescribed limits. The demand that disturbances placed on the process system are such

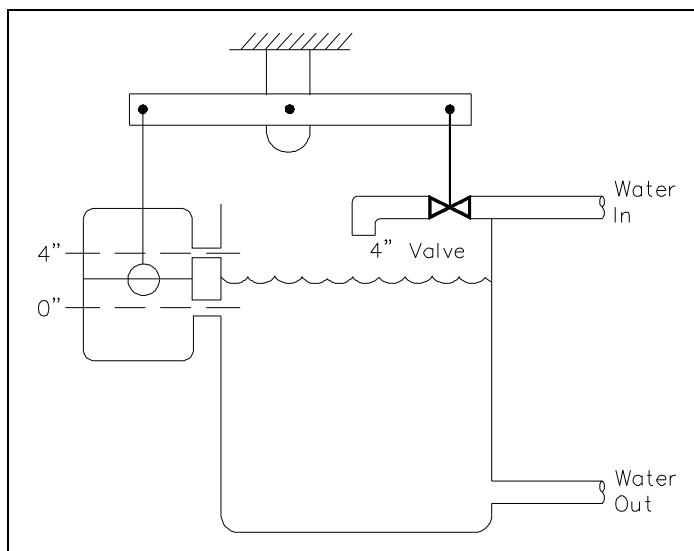

Figure 15 Proportional System Controller

that the actual flow rates cannot be predicted. Therefore, the system is designed to control tank level within a narrow band in order to minimize the chance of a large demand disturbance causing overflow or runout. A fulcrum and lever assembly is used as the proportional controller. A float chamber is the level measuring element, and a 4-in stroke valve is the final control element. The fulcrum point is set such that a level change of 4-in causes a full 4-in stroke of the valve. Therefore, a 100% change in the controller output equals 4-in.

The proportional band is the input band over which the controller provides a proportional output and is defined as follows:

$$\text{Proportional band} = \frac{\% \text{ change in input}}{\% \text{ change in output}} \times 100\%$$

For this example, the fulcrum point is such that a full 4-in change in float height causes a full 4-in stroke of the valve.

$$\text{P.B.} = \frac{100\% \text{ change in input}}{100\% \text{ change in output}} \times 100\%$$

Therefore:

$$\text{P.B.} = 100\%$$

The controller has a proportional band of 100%, which means the input must change 100% to cause a 100% change in the output of the controller.

If the fulcrum setting was changed so that a level change of 2 in, or 50% of the input, causes the full 3-in stroke, or 100% of the output, the proportional band would become 50%. The proportional band of a proportional controller is important because it determines the range of outputs for given inputs.

Example of a Proportional Process Control System

Figure 16 illustrates a process system using a proportional temperature controller for providing hot water.

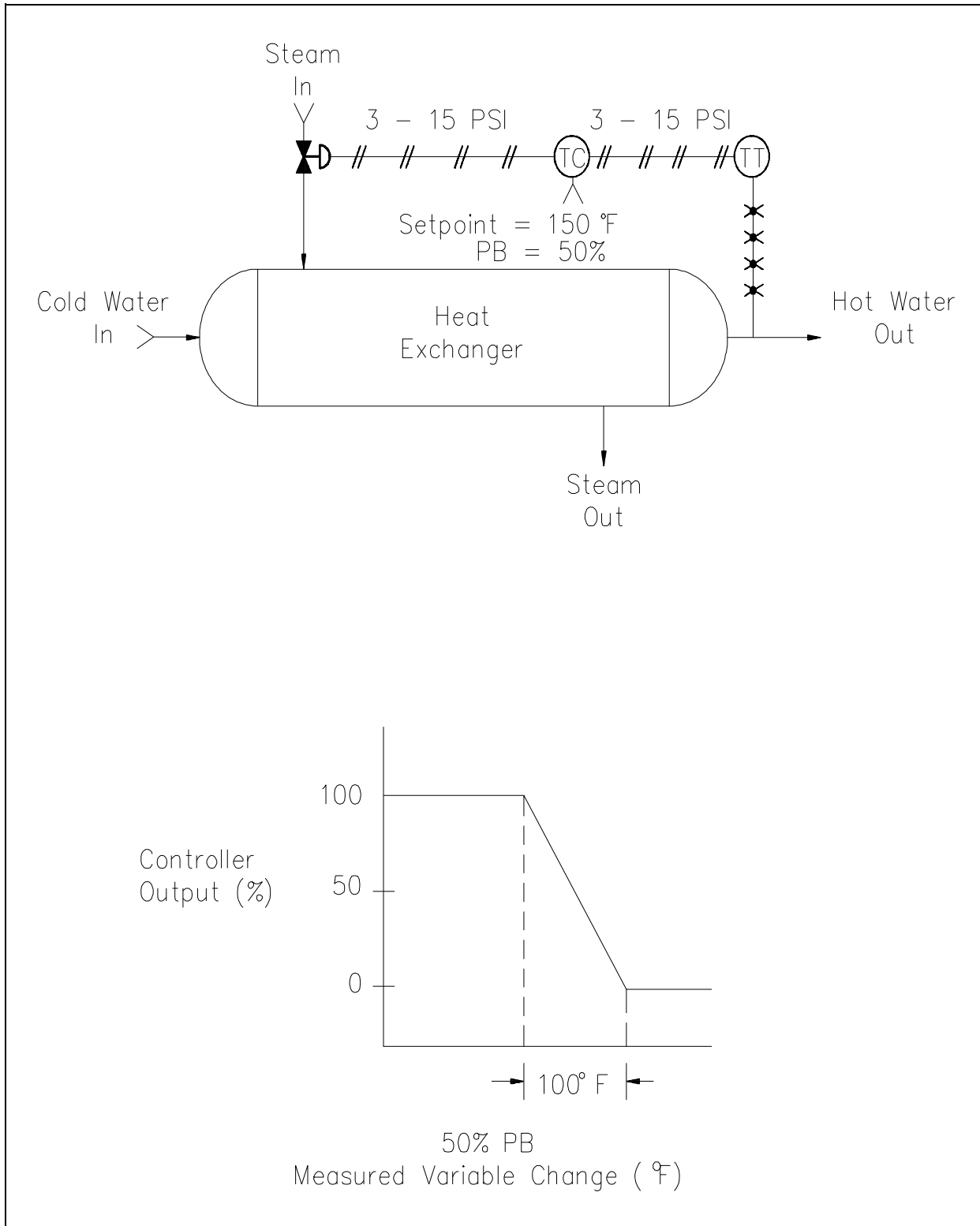

Figure 16 Proportional Temperature Control System

Steam is admitted to the heat exchanger to raise the temperature of the cold water supply. The temperature detector monitors the hot water outlet and produces a 3 to 15 psi output signal that represents a controlled variable range of 100° to 300°F. The controller compares the measured variable signal with the setpoint and sends a 3 to 15 psi output to the final control element, which is a 3-in control valve.

The controller has been set for a proportional band of 50%. Therefore, a 50% change in the 200°F span, or a change of 100°F, causes a 100% controller output change.

The proportional controller is reverse-acting so that the control valve throttles down to reduce steam flow as the hot water outlet temperature increases; the control valve will open further to increase steam flow as the water temperature decreases.

The combined action of the controller and control valve for different changes in the measured variable is shown in Figure 17.

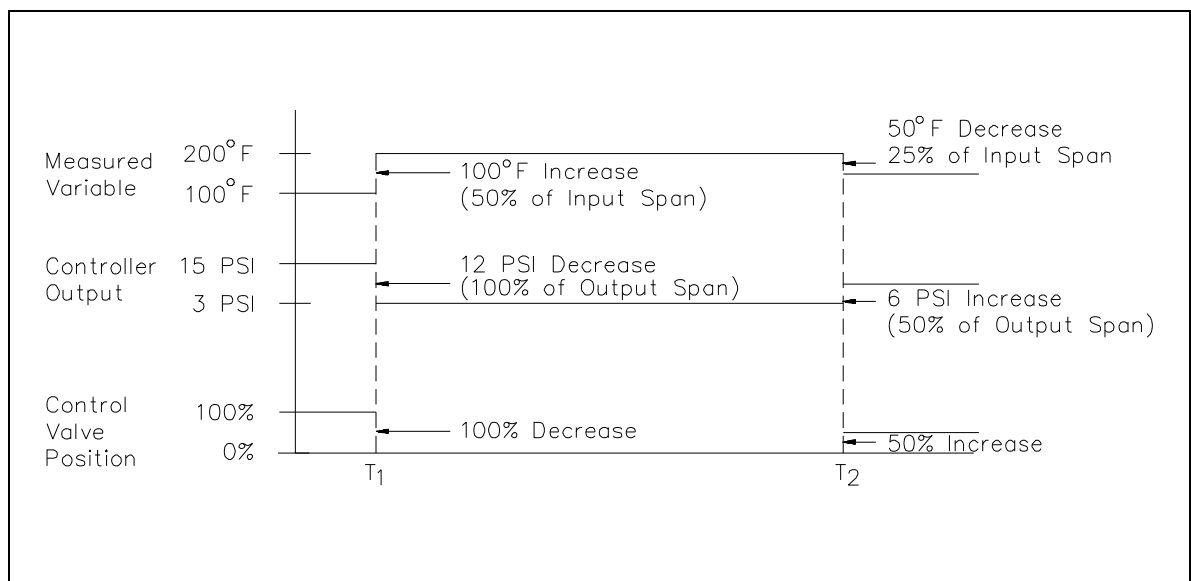

Figure 17 Combined Controller and Final Control Element Action

Initially, the measured variable value is equal to 100°F. The controller has been set so that this value of measured variable corresponds to a 100% output, or 15 psi, which in turn, corresponds to a "full open" control valve position.

At time t_1 , the measured variable increases by 100°F, or 50%, of the measured variable span. This 50% controller input change causes a 100% controller output change due to the controller's proportional band of 50%. The direction of the controller output change is decreasing because the controller is reverse-acting. The 100% decrease corresponds to a decrease in output for 15 psi to 3 psi, which causes the control valve to go from fully open to fully shut.

At time t_2 , the measured variable decreases by 50°F , or 25%, of the measured variable span. The 25% controller input decrease causes a 50% controller output increase. This results in a controller output increase from 3 psi to 9 psi, and the control valve goes from fully shut to 50% open.

The purpose of this system is to provide hot water at a setpoint of 150°F . The system must be capable of handling demand disturbances that can result in the outlet temperature increasing or decreasing from the setpoint. For that reason, the controller is set up such that the system functions as shown in Figure 18.

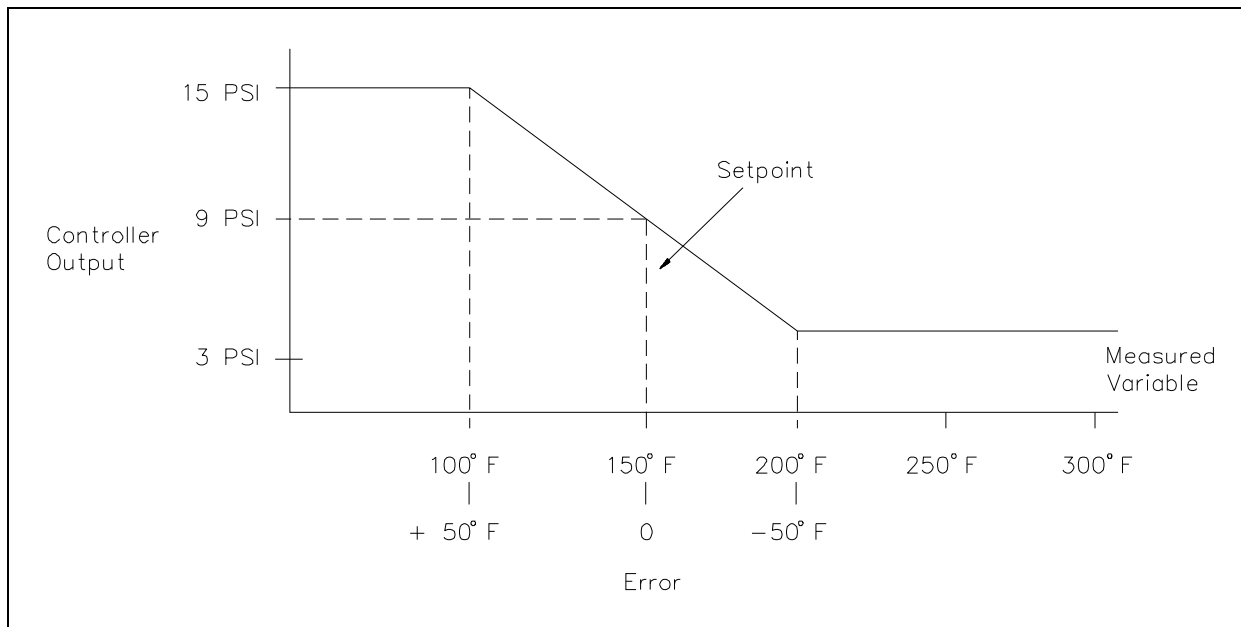

Figure 18 Controller Characteristic Curve

If the measured variable drops below the setpoint, a positive error is developed, and the control valve opens further. If the measured variable goes above the setpoint, a negative error is developed, and the control valve throttles down (opening is reduced). The 50% proportional band causes full stroke of the valve between a $+50^\circ\text{F}$ error and a -50°F error.

When the error equals zero, the controller provides a 50%, or 9 psi, signal to the control valve. As the error goes above and below this point, the controller produces an output that is proportional to the magnitude of the error, determined by the value of the proportional band. The control valve is then capable of being positioned to compensate for the demand disturbances that can cause the process to deviate from the setpoint in either direction.

Summary

The important information in this chapter is summarized below.

Proportional Control Summary

- In the proportional control mode, the final control element is throttled to various positions that are dependent on the process system conditions.
- With proportional control, the output has a linear relationship with the input.
- The proportional band is the change in input required to produce a full range of change in the output due to the proportional control action.
- The controlled variable is maintained within a specified band of control points around a setpoint.

RESET (INTEGRAL) CONTROL SYSTEMS

The output rate of change of an integral controller is dependent on the magnitude of the input.

- EO 1.4** **DESCRIBE the characteristics of the following types of automatic control systems:**
- c. Integral control**
-

Reset Control (Integral)

Integral control describes a controller in which the output rate of change is dependent on the magnitude of the input. Specifically, a smaller amplitude input causes a slower rate of change of the output. This controller is called an integral controller because it approximates the mathematical function of integration. The integral control method is also known as reset control.

Definition of Integral Control

A device that performs the mathematical function of integration is called an integrator. The mathematical result of integration is called the integral. The integrator provides a linear output with a rate of change that is directly related to the amplitude of the step change input and a constant that specifies the function of integration.

For the example shown in Figure 19, the step change has an amplitude of 10%, and the constant of the integrator causes the output to change 0.2% per second for each 1% of the input.

The integrator acts to transform the step change into a gradually changing signal. As you can see, the input amplitude is repeated in the output every 5 seconds. As long as the input remains constant at 10%, the output will continue to ramp up every 5 seconds until the integrator saturates.

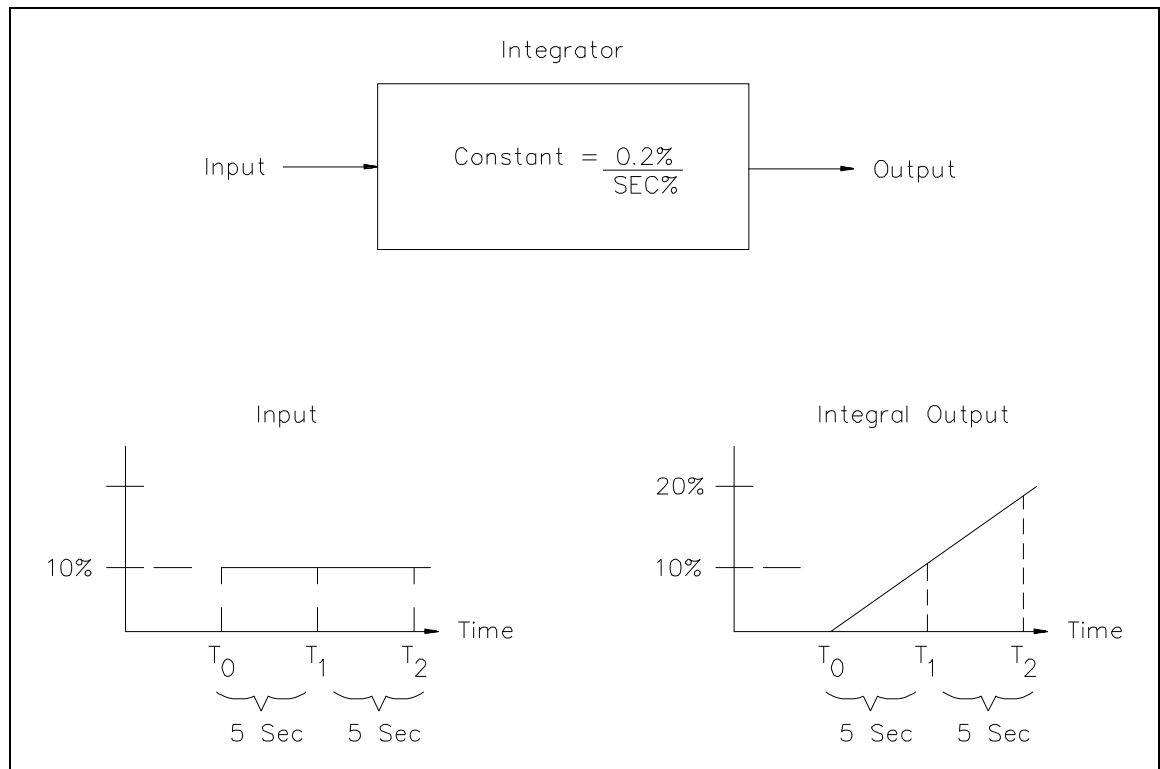

Figure 19 Integral Output for a Fixed Input

Example of an Integral Flow Control System

With integral control, the final control element's position changes at a rate determined by the amplitude of the input error signal. Recall that:

$$\text{Error} = \text{Setpoint} - \text{Measured Variable}$$

If a large difference exists between the setpoint and the measured variable, a large error results. This causes the final control element to change position rapidly. If, however, only a small difference exists, the small error signal causes the final control element to change position slowly.

Figure 20 illustrates a process using an integral controller to maintain a constant flow rate. Also included is the equivalent block diagram of the controller.

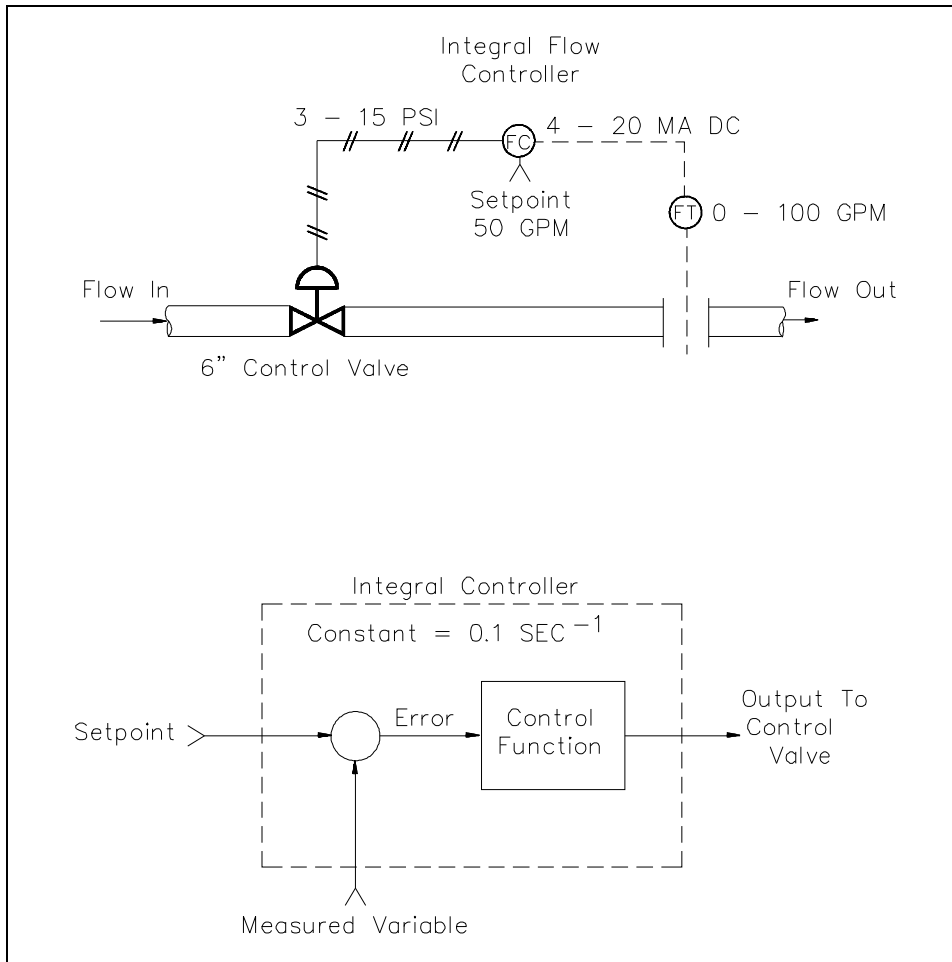

Figure 20 Integral Flow Rate Controller

Initially, the system is set up on an anticipated flow demand of 50 gpm, which corresponds to a control valve opening of 50%. With the setpoint equal to 50 gpm and the actual flow measured at 50 gpm, a zero error signal is sent to the input of the integral controller. The controller output is initially set for a 50%, or 9 psi, output to position the 6-in control valve to a position of 3 in open. The output rate of change of this integral controller is given by:

$$\text{Output rate of change} = \text{Integral constant} \times \% \text{ Error}$$

If the measured variable decreases from its initial value of 50 gpm to a new value of 45 gpm, as seen in Figure 21, a positive error of 5% is produced and applied to the input of the integral controller. The controller has a constant of 0.1 seconds⁻¹, so the controller output rate of change is 0.5% per second.

The positive 0.5% per second indicates that the controller output increases from its initial point of 50% at 0.5% per second. This causes the control valve to open further at a rate of 0.5% per second, increasing flow.

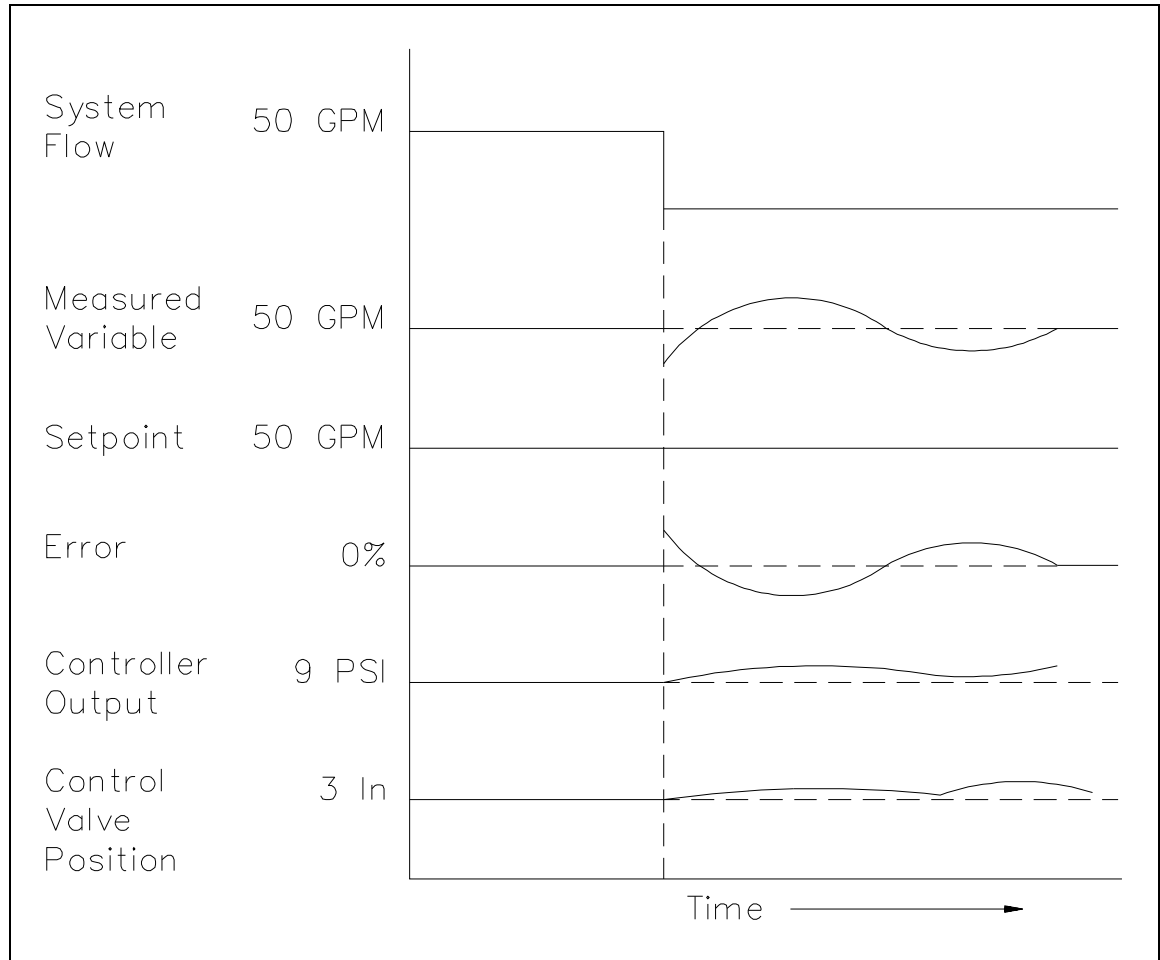

Figure 21 Reset Controller Response

The controller acts to return the process to the setpoints. This is accomplished by the repositioning of the control valve. As the controller causes the control valve to reposition, the measured variable moves closer to the setpoint, and a new error signal is produced. The cycle repeats itself until no error exists.

The integral controller responds to both the amplitude and the time duration of the error signal. Some error signals that are large or exist for a long period of time can cause the final control element to reach its "fully open" or "fully shut" position before the error is reduced to zero. If this occurs, the final control element remains at the extreme position, and the error must be reduced by other means in the actual operation of the process system.

Properties of Integral Control

The major advantage of integral controllers is that they have the unique ability to return the controlled variable back to the exact setpoint following a disturbance.

Disadvantages of the integral control mode are that it responds relatively slowly to an error signal and that it can initially allow a large deviation at the instant the error is produced. This can lead to system instability and cyclic operation. For this reason, the integral control mode is not normally used alone, but is combined with another control mode.

Summary

Integral controllers are summarized below.

Integral Control Summary

- An integral controller provides an output rate of change that is determined by the magnitude of the error and the integral constant.
- The controller has the unique ability to return the process back to the exact setpoint.
- The integral control mode is not normally used by itself because of its slow response to an error signal.

PROPORTIONAL PLUS RESET CONTROL SYSTEMS

Proportional plus reset control is a combination of the proportional and integral control modes.

- EO 1.4** **DESCRIBE** the characteristics of the following types of automatic control systems:
- d.** **Proportional plus reset control system**

Proportional Plus Reset

This type control is actually a combination of two previously discussed control modes, proportional and integral. Combining the two modes results in gaining the advantages and compensating for the disadvantages of the two individual modes.

The main advantage of the proportional control mode is that an immediate proportional output is produced as soon as an error signal exists at the controller as shown in Figure 22. The proportional controller is considered a fast-acting device. This immediate output change enables the proportional controller to reposition the final control element within a relatively short period of time in response to the error.

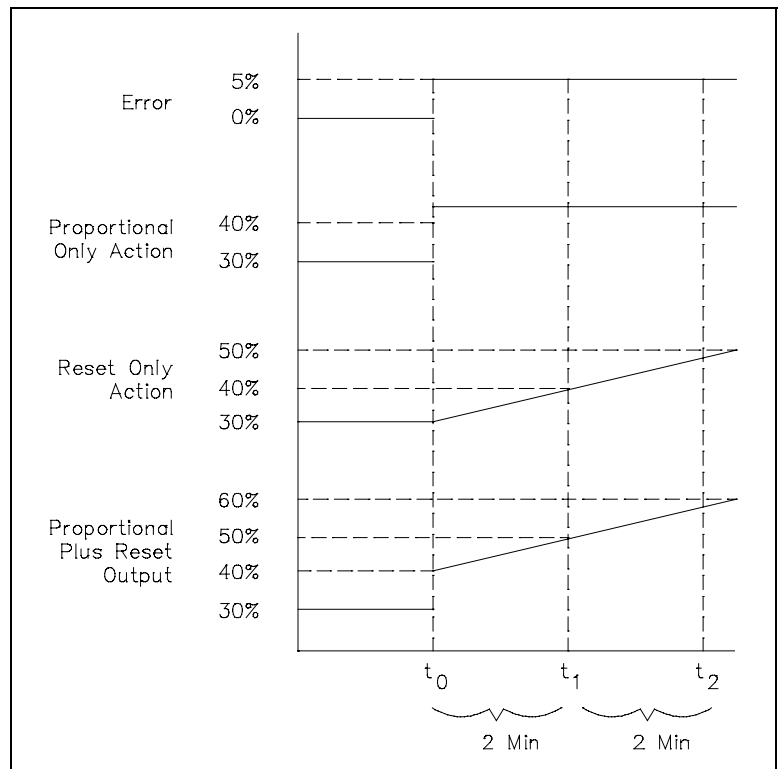

Figure 22 Response of Proportional Plus Reset Control

The main disadvantage of the proportional control mode is that a residual offset error exists between the measured variable and the setpoint for all but one set of system conditions.

The main advantage of the integral control mode is that the controller output continues to reposition the final control element until the error is reduced to zero. This results in the elimination of the residual offset error allowed by the proportional mode.

The main disadvantage of the integral mode is that the controller output does not immediately direct the final control element to a new position in response to an error signal. The controller output changes at a defined rate of change, and time is needed for the final control element to be repositioned.

The combination of the two control modes is called the proportional plus reset (PI) control mode. It combines the immediate output characteristics of a proportional control mode with the zero residual offset characteristics of the integral mode.

Example of Proportional Plus Reset Control

Let's once more refer to our heat exchanger example (see Figure 23). This time we will apply a proportional plus reset controller to the process system.

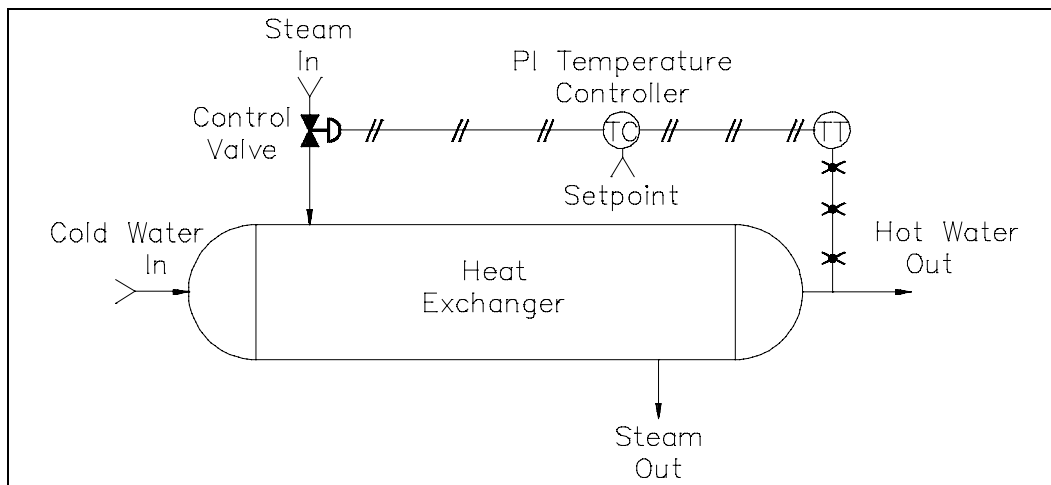

Figure 23 Heat Exchanger Process System

The response curves shown in Figure 24 illustrate only the demand and the measured variable which represents the hot water outlet temperature.

Assume the process undergoes a demand disturbance which reduces the flow of the hot water out of the heat exchanger. The temperature and flow rate of the steam into the heat exchanger remain the same. As a result, the temperature of the hot water out will begin to rise.

The proportional action of the proportional plus reset controller, if acting alone, would respond to the disturbance and reposition the control valve to a position that would return the hot water out to a new control point, as illustrated by the response curves. You'll note that a residual error would still exist.

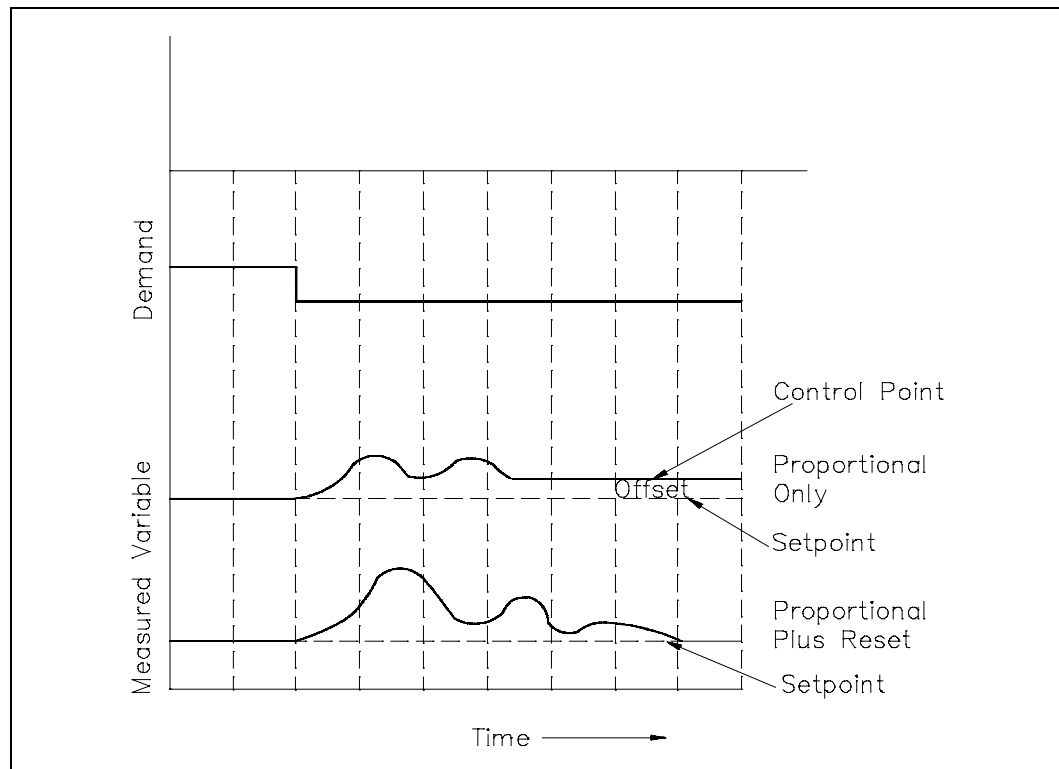

Figure 24 Effects of Disturbance on Reverse Acting Controller

By adding the reset action to the proportional action the controller produces a larger output for the given error signal and causes a greater adjustment of the control valve. This causes the process to come back to the setpoint more quickly. Additionally, the reset action acts to eliminate the offset error after a period of time.

Reset Windup

Proportional plus reset controllers act to eliminate the offset error found in proportional control by continuing to change the output after the proportional action is completed and by returning the controlled variable to the setpoint.

An inherent disadvantage to proportional plus reset controllers is the possible adverse effects caused by large error signals. The large error can be caused by a large demand deviation or when initially starting up the system. This is a problem because a large sustained error signal will eventually cause the controller to drive to its limit, and the result is called "reset windup."

Because of reset windup, this control mode is not well-suited for processes that are frequently shut down and started up.

Summary

The proportional plus reset control mode is summarized below.

Proportional Plus Reset Control Summary

- Proportional plus reset control eliminates any offset error that would occur with proportional control only.
- Reset windup is an inherent disadvantage of proportional plus reset controllers that are subject to large error signals.

PROPORTIONAL PLUS RATE CONTROL SYSTEMS

Proportional plus rate control is a control mode in which a derivative section is added to the proportional controller.

EO 1.4 DESCRIBE the characteristics of the following types of automatic control systems:

e. Proportional plus rate control

Proportional-Derivative

Proportional plus rate describes a control mode in which a derivative section is added to a proportional controller. This derivative section responds to the rate of change of the error signal, not the amplitude; this derivative action responds to the rate of change the instant it starts. This causes the controller output to be initially larger in direct relation with the error signal rate of change. The higher the error signal rate of change, the sooner the final control element is positioned to the desired value. The added derivative action reduces initial overshoot of the measured variable, and therefore aids in stabilizing the process sooner.

This control mode is called proportional plus rate (PD) control because the derivative section responds to the rate of change of the error signal.

Definition of Derivative Control

A device that produces a derivative signal is called a differentiator. Figure 25 shows the input versus output relationship of a differentiator.

The differentiator provides an output that is directly related to the rate of change of the input and a constant that specifies the function of differentiation. The derivative constant is expressed in units of seconds and defines the differential controller output.

The differentiator acts to transform a changing signal to a constant magnitude signal as shown in Figure 26. As long as the input rate of change is constant, the magnitude of the output is constant. A new input rate of change would give a new output magnitude.

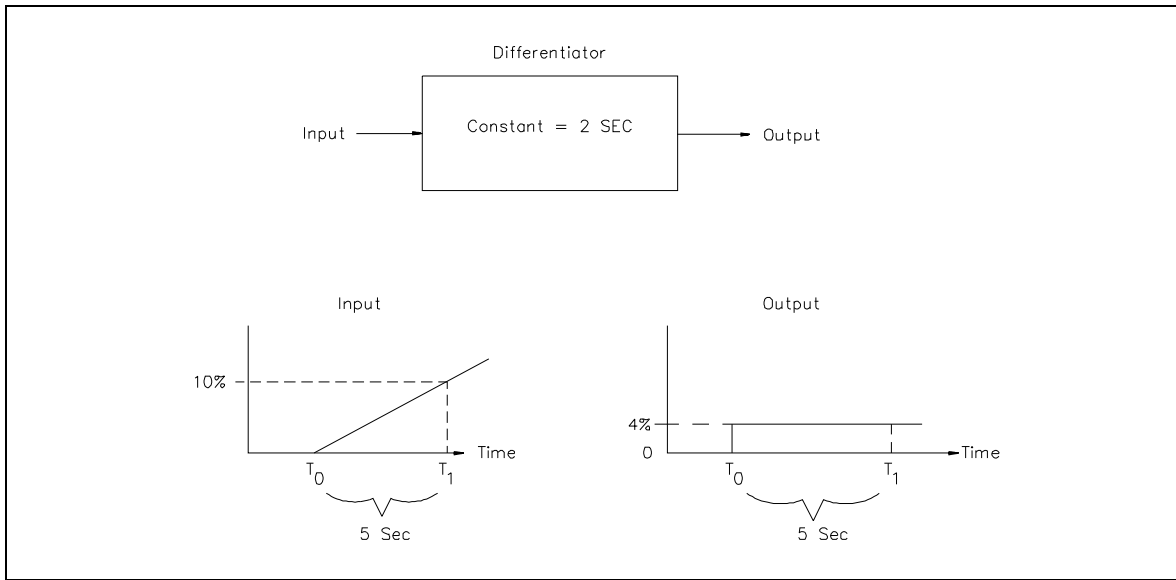

Figure 25 Derivative Output for a Constant Rate of Change Input

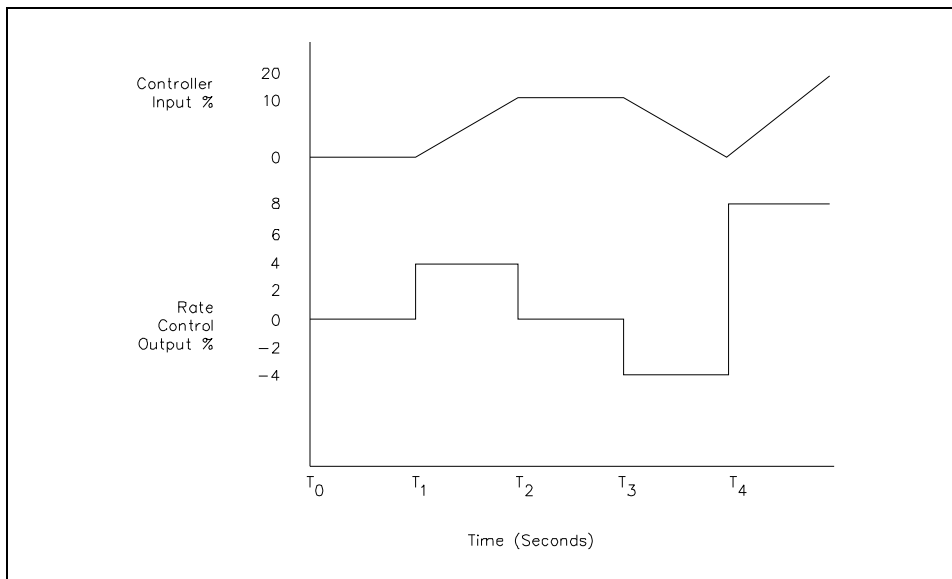

Figure 26 Rate Control Output

Derivative cannot be used alone as a control mode. This is because a steady-state input produces a zero output in a differentiator. If the differentiator were used as a controller, the input signal it would receive is the error signal. As just described, a steady-state error signal corresponds to any number of necessary output signals for the positioning of the final control element. Therefore, derivative action is combined with proportional action in a manner such that the proportional section output serves as the derivative section input.

Proportional plus rate controllers take advantage of both proportional and rate control modes.

As seen in Figure 27, proportional action provides an output proportional to the error. If the error is not a step change, but is slowly changing, the proportional action is slow. Rate action, when added, provides quick response to the error.

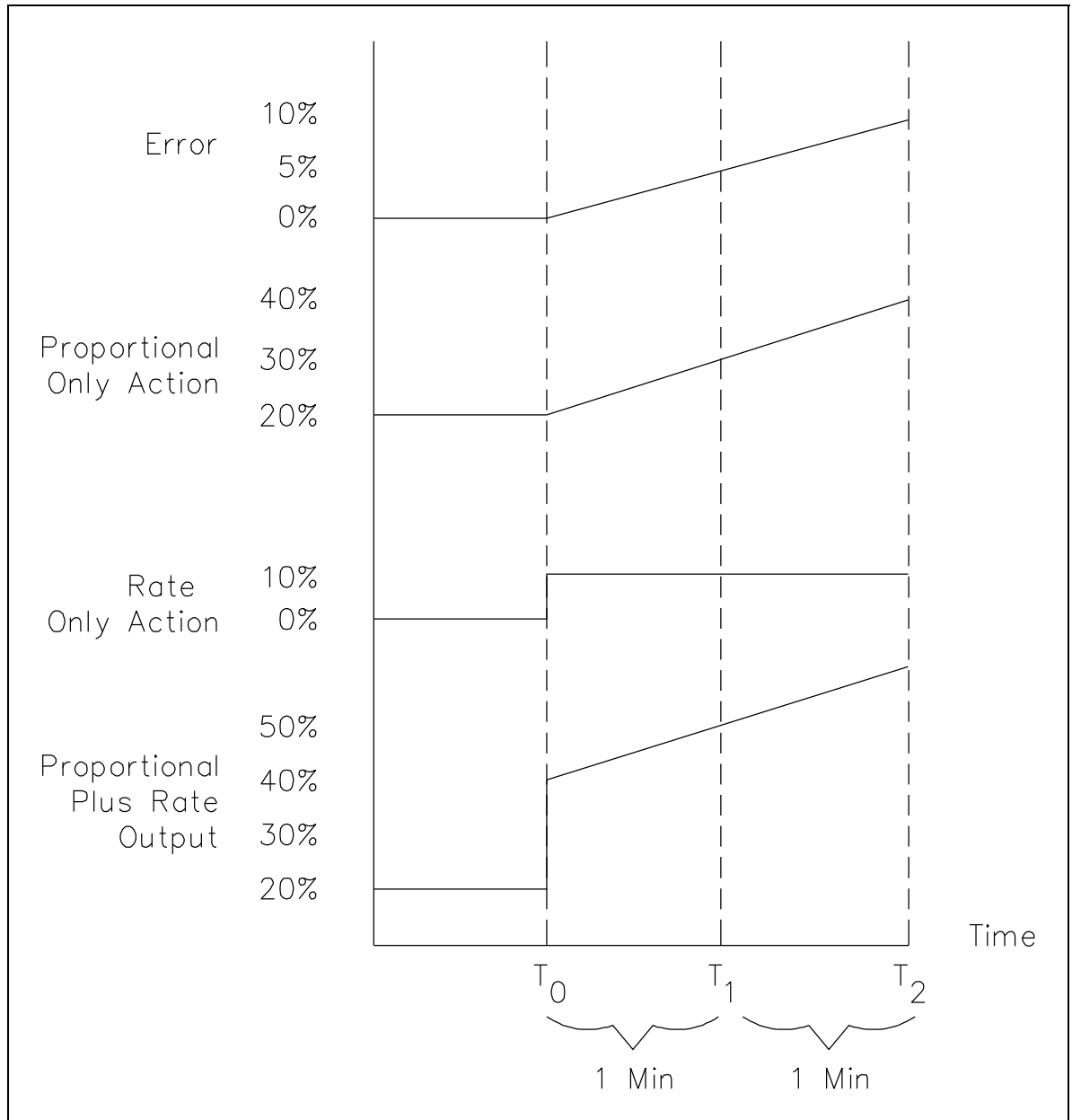

Figure 27 Response of Proportional Plus Rate Control

Example of Proportional Plus Rate Control

To illustrate proportional plus rate control, we will use the same heat exchanger process that has been analyzed in previous chapters (see Figure 28). For this example, however, the temperature controller used is a proportional plus rate controller.

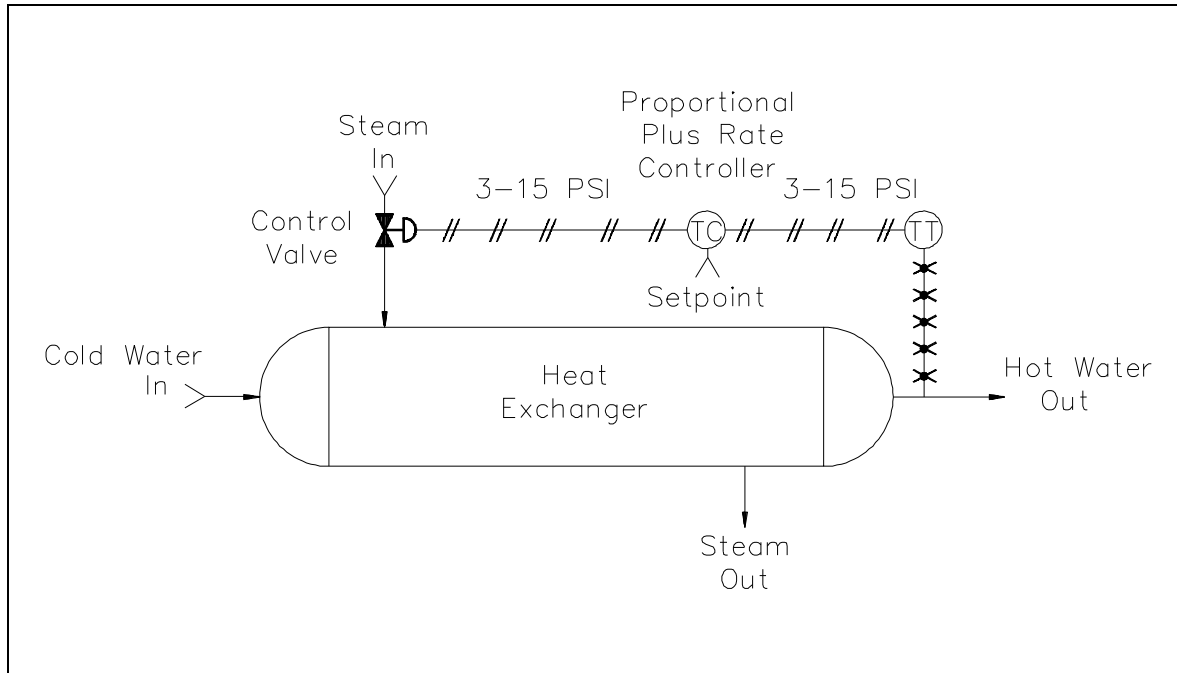

Figure 28 Heat Exchanger Process

As illustrated in Figure 29, the proportional only control mode responds to the decrease in demand, but because of the inherent characteristics of proportional control, a residual offset error remains. Adding the derivative action affects the response by allowing only one small overshoot and a rapid stabilization to the new control point. Thus, derivative action provides increased stability to the system, but does not eliminate offset error.

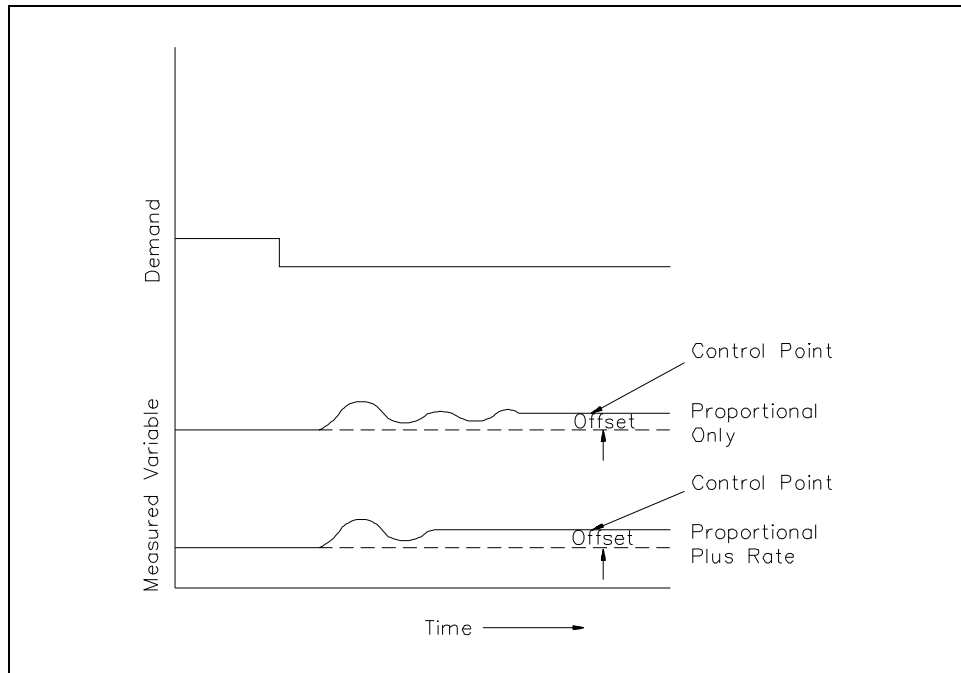

Figure 29 Effect of Disturbance on Proportional Plus Rate Reverse Acting Controller

Applications

Proportional plus rate control is normally used with large capacity or slow-responding processes such as temperature control. The leading action of the controller output compensates for the lagging characteristics of large capacity, slow processes.

Rate action is not usually employed with fast responding processes such as flow control or noisy processes because derivative action responds to any rate of change in the error signal, including the noise.

Proportional plus rate controllers are useful with processes which are frequently started up and shut down because it is not susceptible to reset windup.

Summary

The proportional plus rate control mode is summarized below.

Proportional Plus Rate Control Summary

- Derivative action is added to a controller to make it respond to the rate of change of the error signal.
- Derivative action cannot be used as a control mode alone.
- Proportional plus rate control does not eliminate offset error.
- Proportional plus rate control increases system stability.

PROPORTIONAL-INTEGRAL-DERIVATIVE CONTROL SYSTEMS

Proportional plus reset plus rate controllers combine proportional control actions with integral and derivative actions.

- EO 1.4** **DESCRIBE the characteristics of the following types of automatic control systems:**
- f. **Proportional plus reset plus rate control**
-

Proportional-Integral-Derivative

For processes that can operate with continuous cycling, the relatively inexpensive two position controller is adequate. For processes that cannot tolerate continuous cycling, a proportional controller is often employed. For processes that can tolerate neither continuous cycling nor offset error, a proportional plus reset controller can be used. For processes that need improved stability and can tolerate an offset error, a proportional plus rate controller is employed.

However, there are some processes that cannot tolerate offset error, yet need good stability. The logical solution is to use a control mode that combines the advantages of proportional, reset, and rate action. This chapter describes the mode identified as proportional plus reset plus rate, commonly called Proportional-Integral-Derivative (PID).

Proportional Plus Reset Plus Rate Controller Actions

When an error is introduced to a PID controller, the controller's response is a combination of the proportional, integral, and derivative actions, as shown in Figure 30.

Assume the error is due to a slowly increasing measured variable. As the error increases, the proportional action of the PID controller produces an output that is proportional to the error signal. The reset action of the controller produces an output whose rate of change is determined by the magnitude of the error. In this case, as the error continues to increase at a steady rate, the reset output continues to increase its rate of change. The rate action of the controller produces an output whose magnitude is determined by the rate of change. When combined, these actions produce an output as shown in Figure 30.

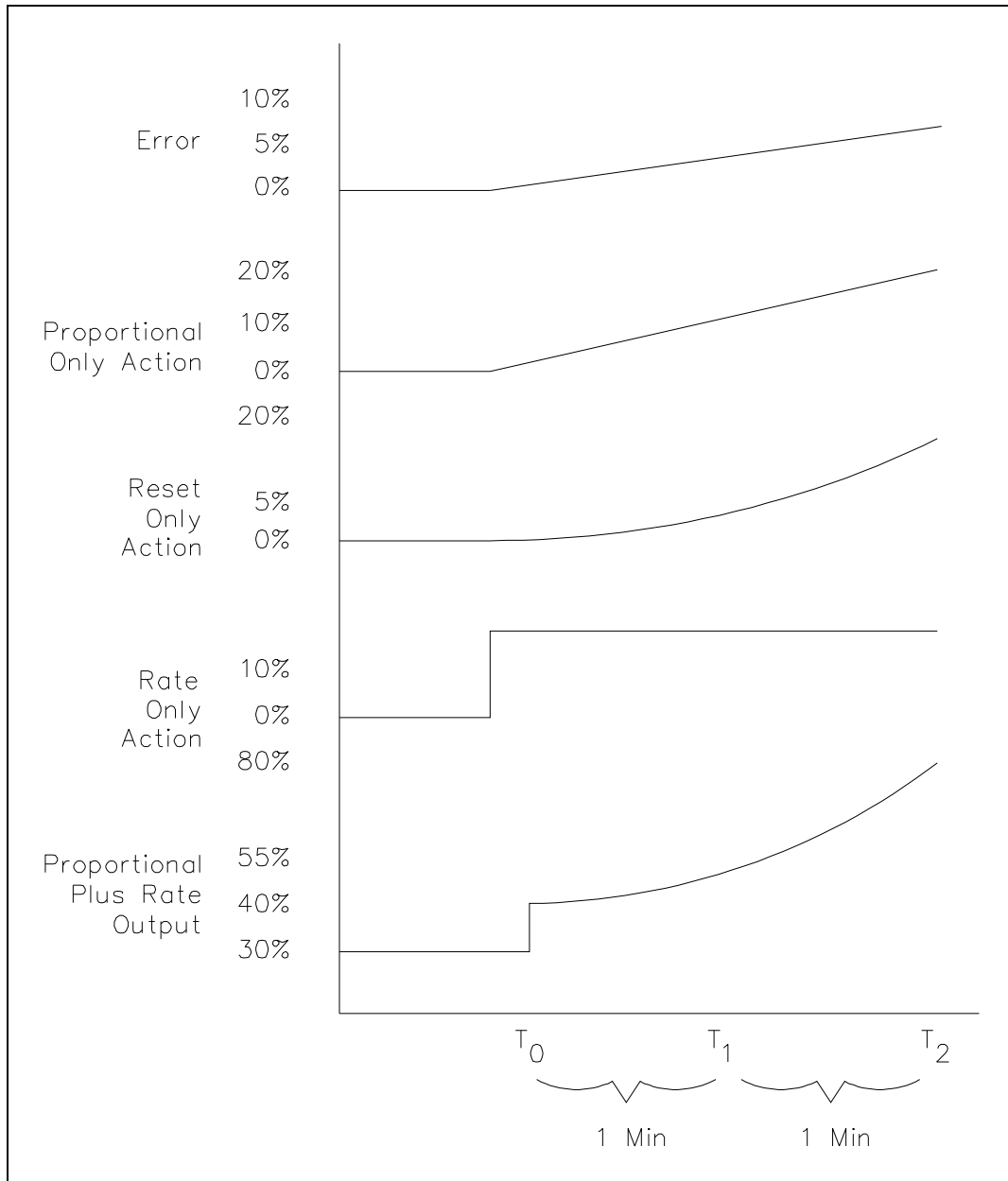

Figure 30 PID Control Action Responses

As you can see from the combined action curve, the output produced responds immediately to the error with a signal that is proportional to the magnitude of the error and that will continue to increase as long as the error remains increasing.

You must remember that these response curves are drawn assuming no corrective action is taken by the control system. In actuality, as soon as the output of the controller begins to reposition the final control element, the magnitude of the error should begin to decrease. Eventually, the controller will bring the error to zero and the controlled variable back to the setpoint.

Figure 31 demonstrates the combined controller response to a demand disturbance. The proportional action of the controller stabilizes the process. The reset action combined with the proportional action causes the measured variable to return to the setpoint. The rate action combined with the proportional action reduces the initial overshoot and cyclic period.

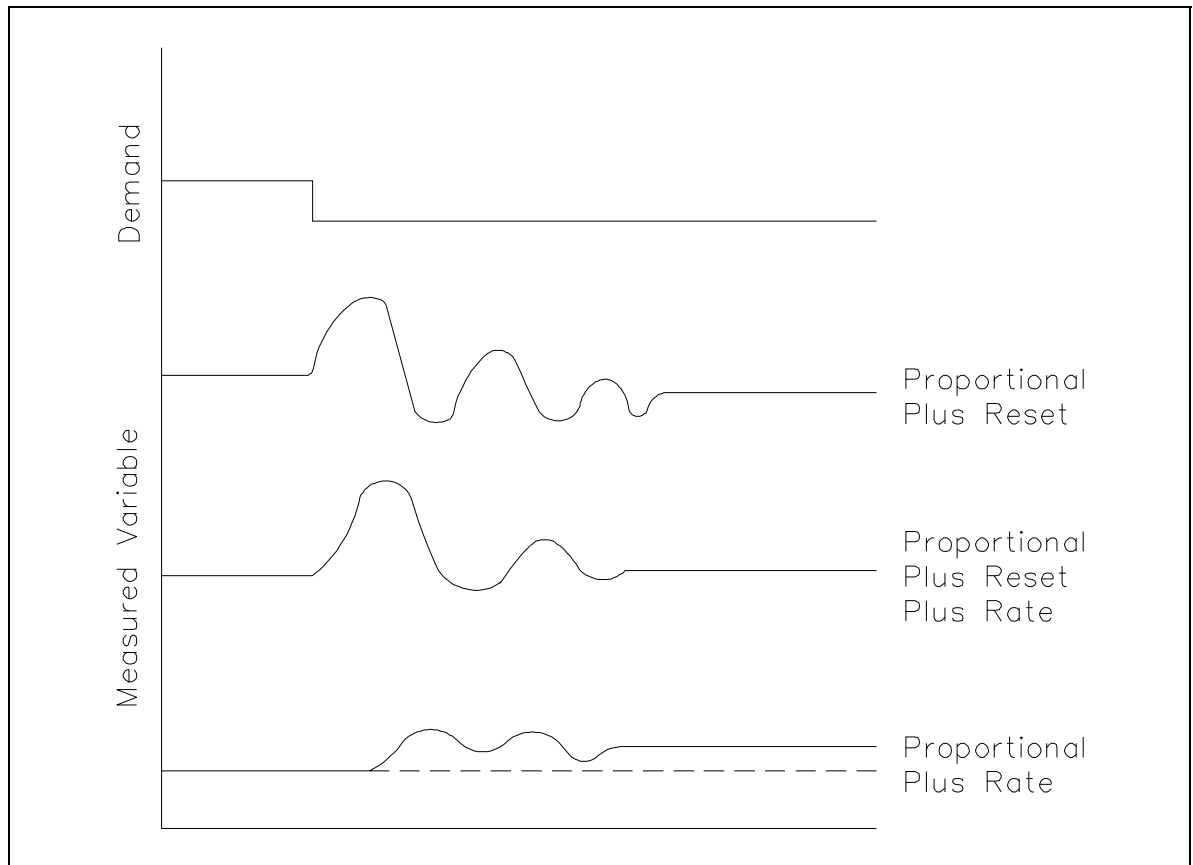

Figure 31 PID Controller Response Curves

Summary

The PID control mode is summarized below.

Proportional Plus Reset Plus Rate Control Summary

- The PID controller combines the three individual modes to achieve the advantages of each.
- The proportional action responds to the error amplitude.
- The integral action eliminates the offset error.
- The derivative action provides additional stability to the process.
- PID controllers can be used to control most processes, even those that are difficult to control.

CONTROLLERS

Mechanical "watchdogs" called controllers are installed in a system to maintain process variables within a given parameter.

EO 1.5 STATE the purpose of the following components of a typical control station:

- a. **Setpoint indicator**
- b. **Setpoint adjustment**
- c. **Deviation indicator**
- d. **Output meter**
- e. **Manual-automatic transfer switch**
- f. **Manual output adjust knob**

EO 1.6 DESCRIBE the operation of a self-balancing control station.

Controllers

Controllers are the controlling element of a control loop. Their function is to maintain a process variable (pressure, temperature, level, etc.) at some desired value. This value may or may not be constant.

The function is accomplished by comparing a setpoint signal (desired value) with the actual value (controlled variable). If the two values differ, an error signal is produced.

The error signal is amplified (increased in strength) to produce a controller output signal. The output signal is sent to a final control element which alters a manipulated variable and returns the controlled variable to setpoint.

This chapter will describe two controllers commonly found in nuclear facility control rooms. Although plants may have other types of controllers, information presented here will generally apply to those controllers as well.

Control Stations

Control stations perform the function of a controller and provide additional controls and indicators to allow an operator to manually adjust the controller output to the final control element.

Figure 32 shows the front panel of a typical control station. It contains several indicators and controls. Each will be discussed.

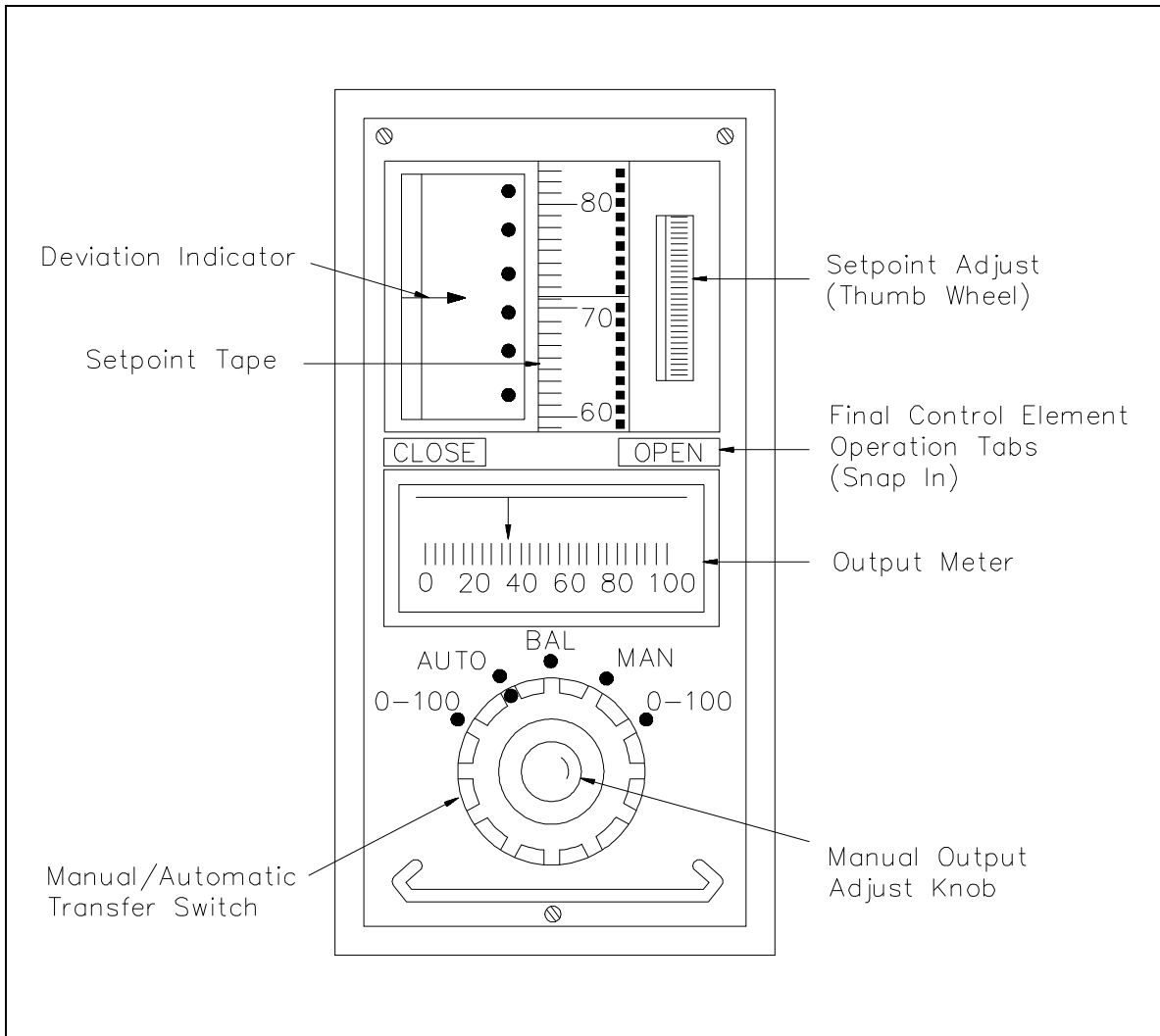

Figure 32 Typical Control Station

The *setpoint indicator*, located in the center of the upper half of the controller, indicates the setpoint (desired value) selected for the controller. The scale may be marked 0% to 100% or correspond directly to the controlled variable (e.g., 0 - 1000 psig or -20°F to +180°F).

The *setpoint adjustment*, located right of the setpoint indicator, is a thumbwheel type adjustment dial that allows the operator to select the setpoint value. By rotating the thumbwheel, the scale moves under the setpoint index line.

The *deviation indicator*, located left of the setpoint indicator, displays any error (+10% to -10%) between setpoint value and actual controlled variable value. With no error, the deviation pointer stays at mid-scale, in line with the setpoint index mark. If the controlled variable is lower than setpoint, the deviation indicator deflects downward. If higher, the indicator deflects upward. An example of this is shown in Figure 33.

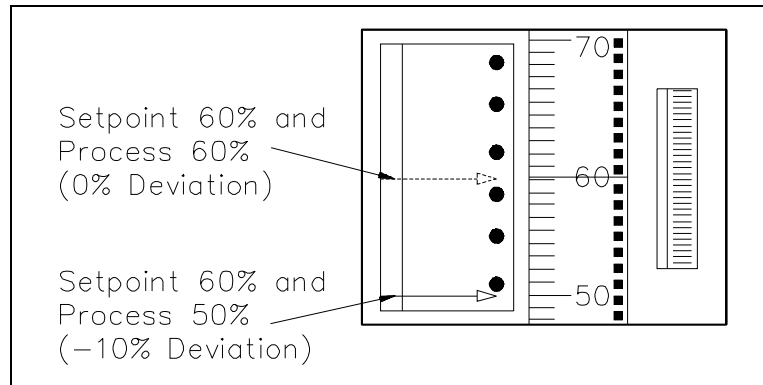

Figure 33 Deviation Indicator

The *output meter* is the horizontally positioned meter below the deviation and setpoint indicators. It indicates controller output signal in percent. This particular controller ranges from zero to 100% current. However, this will correspond to an air signal for pneumatic controllers.

Snap-in tabs, above each end of the output meter, indicate the direction the final control element moves for a change in the output signal. Tabs normally read "open-close" for control valves and "slow-fast" for variable-speed motors, or other appropriate designations.

The *manual-automatic (M-A) transfer switch*, immediately below the output meter, selects operating mode of the controller.

A *manual output adjust knob*, in the center of the M-A transfer switch, varies the controller output signal in manual mode of operation. The knob is rotated clockwise to increase the signal and counterclockwise to decrease the signal.

The M-A transfer switch has five positions that alter the mode of operation. The indication is provided by the deviation meter.

AUTO. This is the normal position of the M-A transfer switch. It places the controller in the automatic mode of operation. Also, the deviation meter indicates any deviation between controlled variable and setpoint.

0 - 100 (AUTO side). In this position, the controller is still in automatic mode. However, the deviation meter now indicates the approximate value of the controlled variable. The deviation meter deflects full down for zero variable value, and full up for 100% variable value.

MAN. This position places the controller in the manual mode of operation. Controller output is now varied by adjusting the manual output adjust knob. This adjustment is indicated on the output meter. The deviation meter indicates any deviation between controlled variable and setpoint.

0 - 100 (MAN side). The controller is still in the manual mode of operation, and the deviation meter indicates controlled variable value (0% to 100%) as it did in the 0-100 (AUTO side) position.

BAL. In many cases, controller output signals of the automatic mode and manual mode may not be the same. If the controller were directly transferred from automatic to manual or manual to automatic, the controller output signal could suddenly change from one value to another. As a result, the final control element would experience a sudden change in position or "bump." This can cause large swings in the value of the process variable and possible damage to the final control element.

Bumpless transfer is the smooth transfer of a controller from one operating mode to another. The balance (BAL) position provides this smooth transfer when transferring the controller from the automatic to manual mode. In the BAL position, the controller is still in the automatic mode of operation, but the deviation meter now indicates the difference between outputs of manual and automatic modes of control. The manual output is adjusted until the deviation meter shows no deflection. Now, the controller can be transferred smoothly from automatic to manual.

To ensure a bumpless transfer from manual to automatic, the manual output signal, indicated by the output meter, is adjusted to match the controlled variable value to setpoint. This will be indicated by no deflection of the deviation meter. Once matched, the M-A transfer switch can be switched from manual (MAN) to automatic (AUTO) control.

Self-Balancing Control Stations

The self-balancing M-A control station shown in Figure 34 has several controls and indicators that are basically the same as those shown on the M-A control station in Figure 32. However, there are some which differ. In addition, the controller does not require a balancing procedure prior to shifting from one mode (manual or automatic) to another.

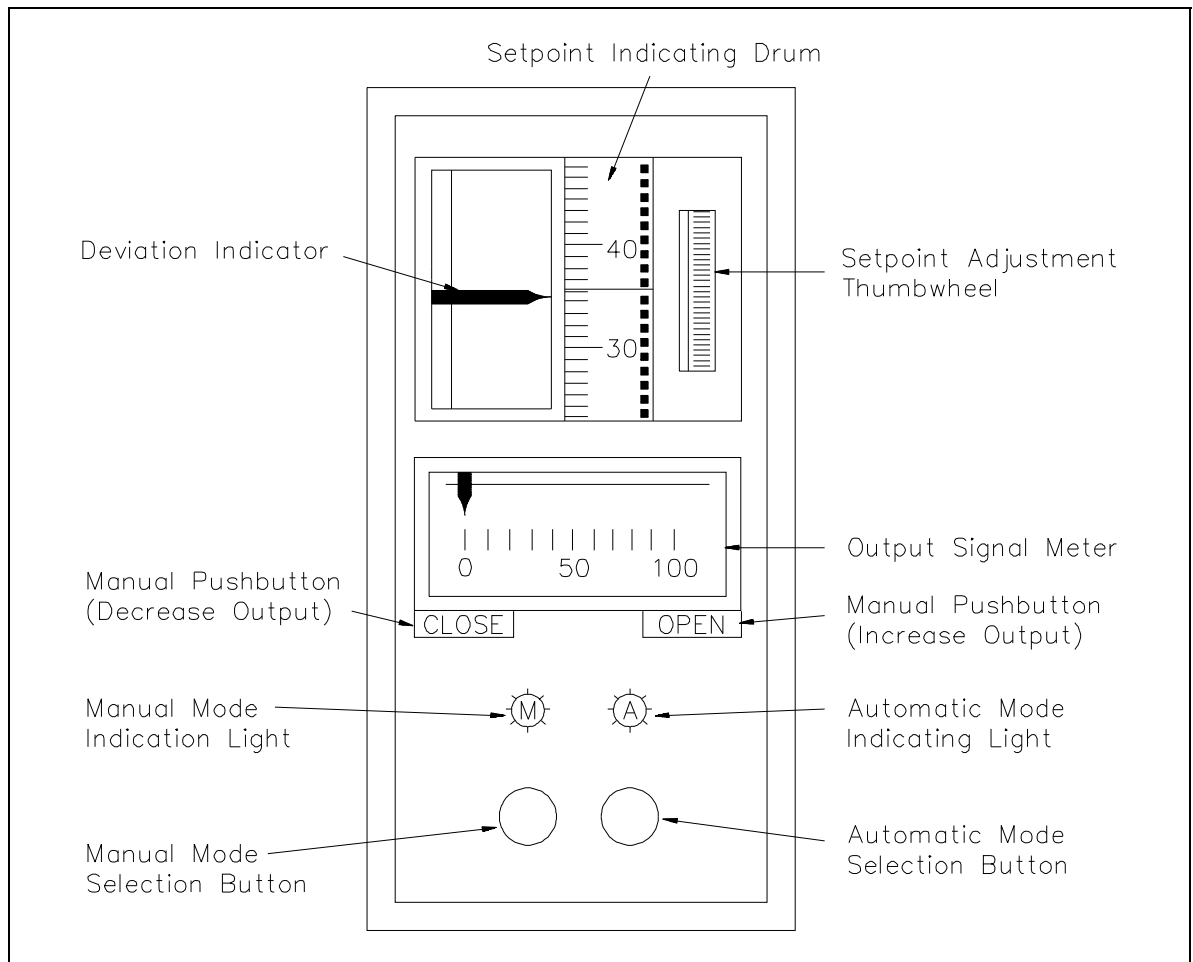

Figure 34 Self-Balancing Control Station

Self-balancing describes a control station in which the non-operating mode output signal follows (tracks) the operating mode output signal. When the control station is in the automatic mode, the manual output signal will follow the automatic output signal. Once the controller is transferred to the manual mode, the output signal will remain at its previous value until one of the manual push buttons (discussed below) is depressed. Then, the output will vary. When the controller is in manual mode, the automatic output signal will track the manual output signal. Once the controller is transferred from the manual to automatic mode, the automatic output signal will initially remain at the manual mode value. If a deviation did exist in the manual mode, the automatic output signal would change slowly and return the controlled variable to setpoint.

The deviation indicator, setpoint indicator, setpoint adjustment thumbwheel, and output meter of the controller in Figure 34 function essentially the same as those in Figure 32. The remaining controls and indicators are quite different. Therefore, each will be discussed.

Manual push buttons. These buttons are located below each end of the output meter and are used in the manual mode of operation. Buttons are labeled to indicate their effect on the final control element. The labels are "open-close" for valves and "slow-fast" for variable speed devices. The left push button decreases the output signal. The right push button increases the output signal. Either button can be depressed at two different positions, half-in and full-in. At the half-in position, the output signal changes slowly. At the full-in position, the output signal changes about ten times faster.

Mode indicating lights. Located directly below the manual push buttons, these lights indicate the operating mode of the controller. When in manual mode, the left light, labeled "M", will be lit; when in the automatic mode, the right light, labeled "A", will be lit.

Mode selection buttons. Located directly under each mode indicating light, each button will select its respective mode of control. If the button below the "M" mode light is depressed, the controller will be in the manual mode of operation; if the button below the "A" mode light is depressed, the controller will be in the automatic mode of operation.

As previously discussed, a particular plant will probably have controllers different from the two described here. Although most information provided can be generally applied, it is extremely important that the operator know the specific plant's controllers and their applications.

Final control elements are devices that complete the control loop. They link the output of the controlling elements with their processes. Some final control elements are designed for specific applications. For example, neutron-absorbing control rods of a reactor are specifically designed to regulate neutron-power level. However, the majority of final control elements are general application devices such as valves, dampers, pumps, and electric heaters. Valves and dampers have similar functions. Valves regulate flow rate of a liquid while dampers regulate flow of air and gases. Pumps, like valves, can be used to control flow of a fluid. Heaters are used to control temperature.

These devices can be arranged to provide a type of "on-off" control to maintain a variable between maximum and minimum values. This is accomplished by opening and shutting valves or dampers or energizing and de-energizing pumps or heaters. On the other hand, these devices can be modulated over a given operating band to provide a proportional control. This is accomplished by positioning valves or dampers, varying the speed of a pump, or regulating the current through electric heater. There are many options to a process control.

Of the final control elements discussed, the most widely used in power plants are valves. Valves can be easily adapted to control liquid level in a tank, temperature of a heat exchanger, or flow rate.

Summary

The important information in this chapter is summarized below.

Controllers Summary

- The *setpoint indicator* displays the desired value for the controller.
- The dial adjustment used to vary the setpoint value is the *setpoint adjustment*.
- The *deviation indicator* displays the difference in percentages between the setpoint value and the actual controlled variable value.
- Percentage display for the output signal is indicated on the *output meter*.
- The *manual-automatic transfer switch* is a five position switch that alters the mode of operation.
- Located in the center of the transfer switch, the *manual output adjustment knob* varies the controller output signal in the manual mode of operation.
- A self-balancing control station's non-operating mode output signal follows the operating mode output signal.

VALVE ACTUATORS

Remote operation of a valve is easily managed by one of the four types of actuators.

EO 1.7 DESCRIBE the operation of the following types of actuators:

- a. **Pneumatic**
- b. **Hydraulic**
- c. **Solenoid**
- d. **Electric motor**

Actuators

By themselves, valves cannot control a process. Manual valves require an operator to position them to control a process variable. Valves that must be operated remotely and automatically require special devices to move them. These devices are called actuators. Actuators may be pneumatic, hydraulic, or electric solenoids or motors.

Pneumatic Actuators

A simplified diagram of a pneumatic actuator is shown in Figure 35. It operates by a combination of force created by air and spring force. The actuator positions a control valve by transmitting its motion through the stem.

A rubber diaphragm separates the actuator housing into two air chambers. The upper chamber receives supply air through an opening in the top of the housing.

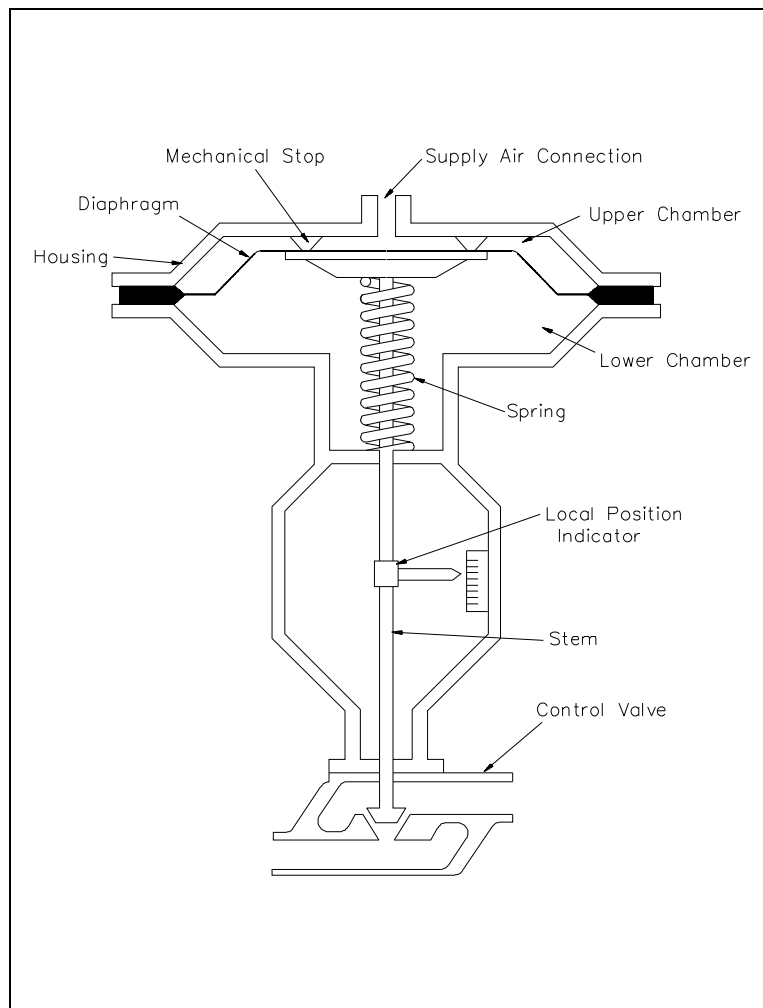

Figure 35 Pneumatic Actuator: Air-to-Close/Spring-to-Open

The bottom chamber contains a spring that forces the diaphragm against mechanical stops in the upper chamber. Finally, a local indicator is connected to the stem to indicate the position of the valve.

The position of the valve is controlled by varying supply air pressure in the upper chamber. This results in a varying force on the top of the diaphragm. Initially, with no supply air, the spring forces the diaphragm upward against the mechanical stops and holds the valve fully open. As supply air pressure is increased from zero, its force on top of the diaphragm begins to overcome the opposing force of the spring. This causes the diaphragm to move downward and the control valve to close. With increasing supply air pressure, the diaphragm will continue to move downward and compress the spring until the control valve is fully closed. Conversely, if supply air pressure is decreased, the spring will begin to force the diaphragm upward and open the control valve. Additionally, if supply pressure is held constant at some value between zero and maximum, the valve will position at an intermediate position. Therefore, the valve can be positioned anywhere between fully open and fully closed in response to changes in supply air pressure.

A positioner is a device that regulates the supply air pressure to a pneumatic actuator. It does this by comparing the actuator's demanded position with the control valve's actual position. The demanded position is transmitted by a pneumatic or electrical control signal from a controller to the positioner. The pneumatic actuator in Figure 35 is shown in Figure 36 with a controller and positioner added.

The controller generates an output signal that represents the demanded position. This signal is sent to the positioner. Externally, the positioner consists of an input connection for the control signal, a supply air input connection, a supply air output connection, a supply air vent connection, and a feedback linkage. Internally, it contains an intricate network of electrical transducers, air lines, valves, linkages, and necessary adjustments. Other positioners may also provide controls for local valve positioning and gauges to indicate supply air pressure and control air pressure (for pneumatic controllers). From an operator's viewpoint, a description of complex internal workings of a positioner is not needed. Therefore, this discussion will be limited to inputs to and outputs from the positioner.

In Figure 36, the controller responds to a deviation of a controlled variable from setpoint and varies the control output signal accordingly to correct the deviation. The control output signal is sent to the positioner, which responds by increasing or decreasing the supply air to the actuator. Positioning of the actuator and control valve is fed back to the positioner through the feedback linkage. When the valve has reached the position demanded by the controller, the positioner stops the change in supply air pressure and holds the valve at the new position. This, in turn, corrects the controlled variable's deviation from setpoint.

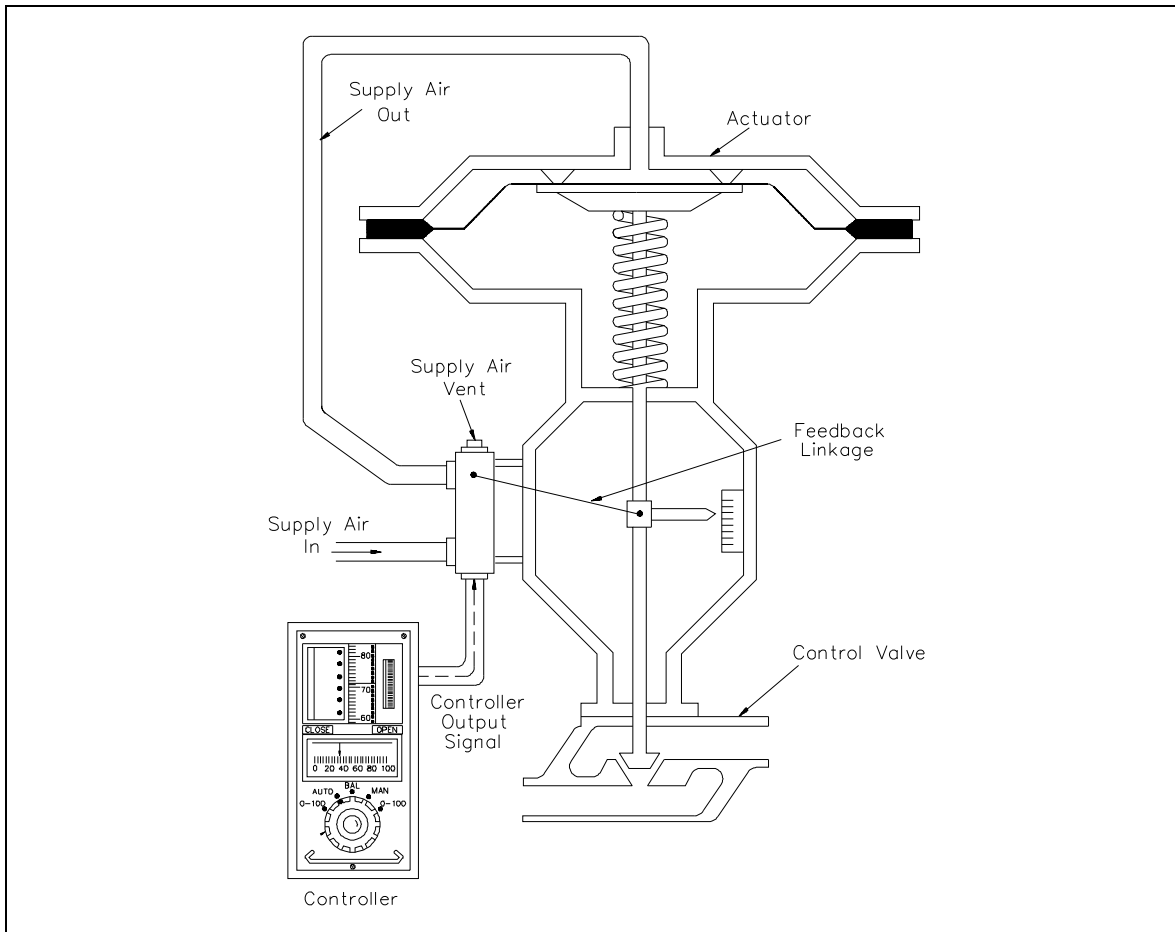

Figure 36 Pneumatic Actuator with Controller and Positioner

For example, as the control signal increases, a valve inside the positioner admits more supply air to the actuator. As a result, the control valve moves downward. The linkage transmits the valve position information back to the positioner. This forms a small internal feedback loop for the actuator. When the valve reaches the position that correlates to the control signal, the linkage stops supply air flow to the actuator. This causes the actuator to stop. On the other hand, if the control signal decreases, another valve inside the positioner opens and allows the supply air pressure to decrease by venting the supply air. This causes the valve to move upward and open. When the valve has opened to the proper position, the positioner stops venting air from the actuator and stops movement of the control valve.

An important safety feature is provided by the spring in an actuator. It can be designed to position a control valve in a safe position if a loss of supply air occurs. On a loss of supply air, the actuator in Figure 36 will fail open. This type of arrangement is referred to as "air-to-close, spring-to-open" or simply "fail-open." Some valves fail in the closed position. This type of actuator is referred to as "air-to-open, spring-to-close" or "fail-closed." This "fail-safe" concept is an important consideration in nuclear facility design.

Hydraulic Actuators

Pneumatic actuators are normally used to control processes requiring quick and accurate response, as they do not require a large amount of motive force. However, when a large amount of force is required to operate a valve (for example, the main steam system valves), hydraulic actuators are normally used. Although hydraulic actuators come in many designs, piston types are most common.

A typical piston-type hydraulic actuator is shown in Figure 37. It consists of a cylinder, piston, spring, hydraulic supply and return line, and stem. The piston slides vertically inside the cylinder and separates the cylinder into two chambers. The upper chamber contains the spring and the lower chamber contains hydraulic oil.

The hydraulic supply and return line is connected to the lower chamber and allows hydraulic fluid to flow to and from the lower chamber of the actuator. The stem transmits the motion of the piston to a valve.

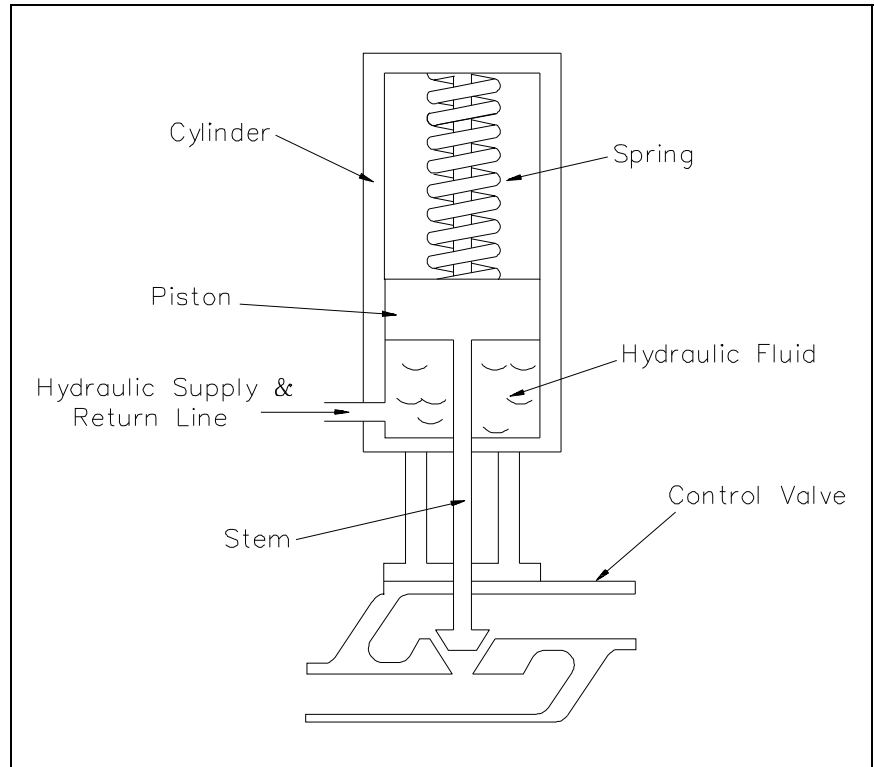

Figure 37 Hydraulic Actuator

Initially, with no hydraulic fluid pressure, the spring force holds the valve in the closed position. As fluid enters the lower chamber, pressure in the chamber increases. This pressure results in a force on the bottom of the piston opposite to the force caused by the spring. When the hydraulic force is greater than the spring force, the piston begins to move upward, the spring compresses, and the valve begins to open. As the hydraulic pressure increases, the valve continues to open. Conversely, as hydraulic oil is drained from the cylinder, the hydraulic force becomes less than the spring force, the piston moves downward, and the valve closes. By regulating amount of oil supplied or drained from the actuator, the valve can be positioned between fully open and fully closed.

The principles of operation of a hydraulic actuator are like those of the pneumatic actuator. Each uses some motive force to overcome spring force to move the valve. Also, hydraulic actuators can be designed to fail-open or fail-closed to provide a fail-safe feature.

Electric Solenoid Actuators

A typical electric solenoid actuator is shown in Figure 38. It consists of a coil, armature, spring, and stem.

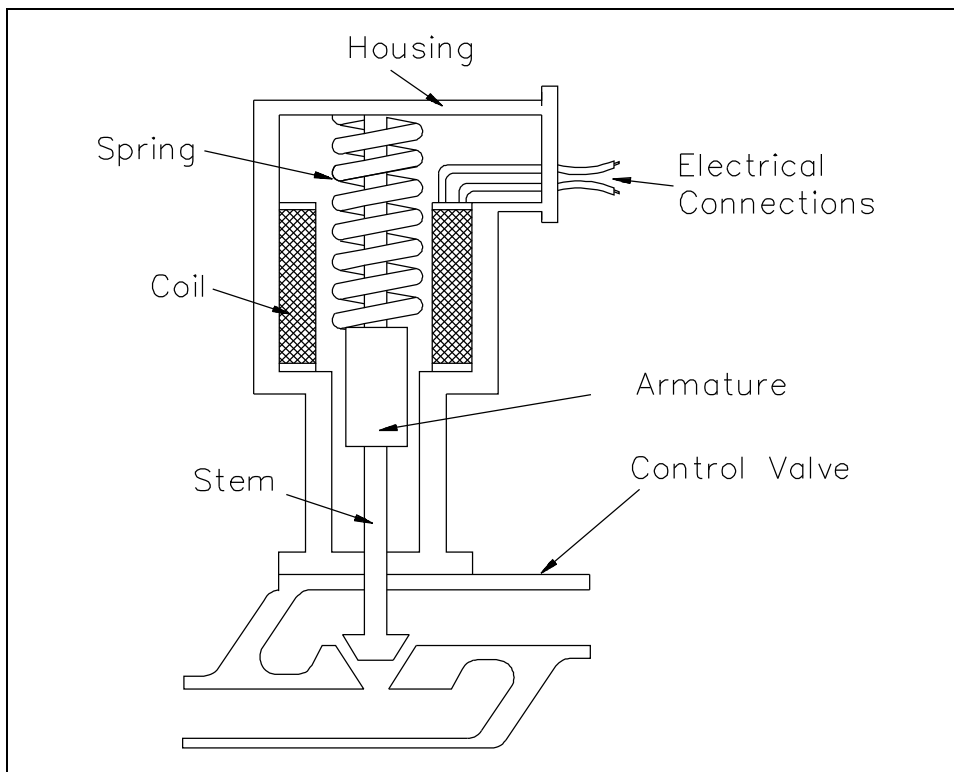

Figure 38 Electric Solenoid Actuator

The coil is connected to an external current supply. The spring rests on the armature to force it downward. The armature moves vertically inside the coil and transmits its motion through the stem to the valve.

When current flows through the coil, a magnetic field forms around the coil. The magnetic field attracts the armature toward the center of the coil. As the armature moves upward, the spring collapses and the valve opens. When the circuit is opened and current stops flowing to the coil, the magnetic field collapses. This allows the spring to expand and shut the valve.

A major advantage of solenoid actuators is their quick operation. Also, they are much easier to install than pneumatic or hydraulic actuators. However, solenoid actuators have two disadvantages. First, they have only two positions: fully open and fully closed. Second, they don't produce much force, so they usually only operate relatively small valves.

Electric Motor Actuators

Electric motor actuators vary widely in their design and applications. Some electric motor actuators are designed to operate in only two positions (fully open or fully closed). Other electric motors can be positioned between the two positions. A typical electric motor actuator is shown in Figure 39. Its major parts include an electric motor, clutch and gear box assembly, manual handwheel, and stem connected to a valve.

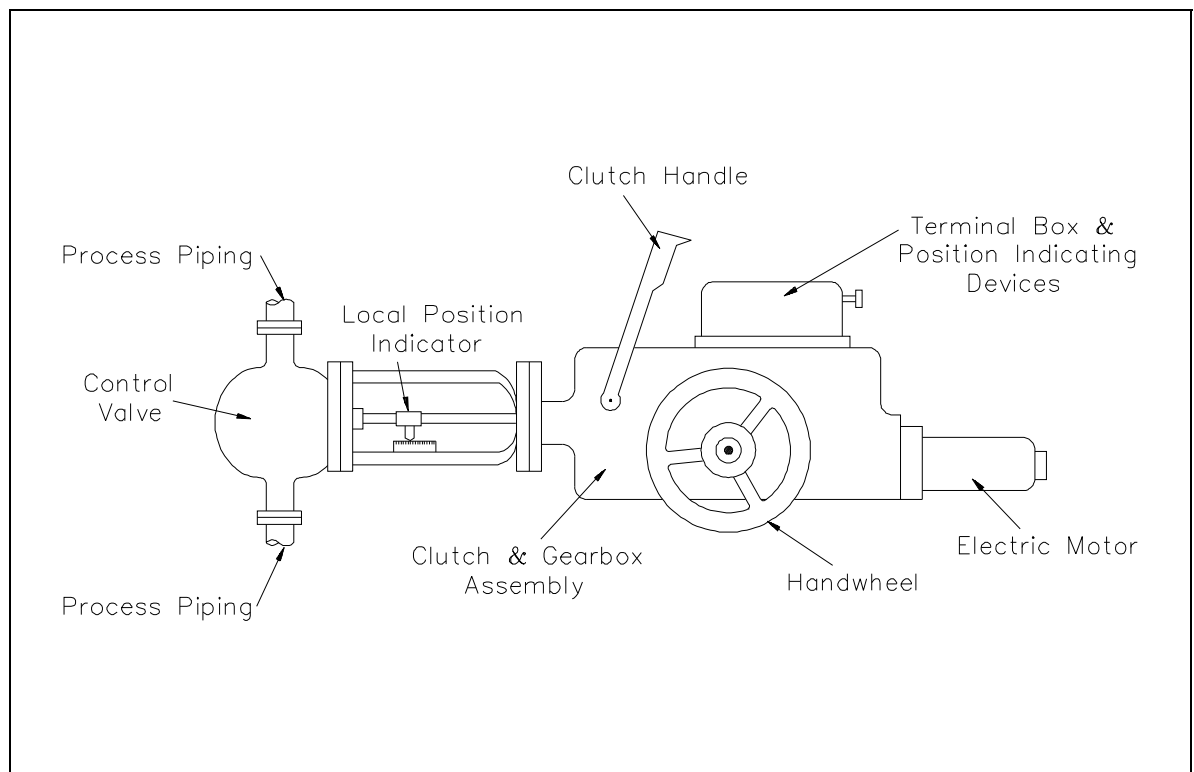

Figure 39 Electric Motor Actuator

The motor moves the stem through the gear assembly. The motor reverses its rotation to either open or close the valve. The clutch and clutch lever disconnects the electric motor from the gear assembly and allows the valve to be operated manually with the handwheel.

Most electric motor actuators are equipped with limit switches, torque limiters, or both. Limit switches de-energize the electric motor when the valve has reached a specific position. Torque

limiters de-energize the electric motor when the amount of turning force has reached a specified value. The turning force normally is greatest when the valve reaches the fully open or fully closed position. This feature can also prevent damage to the actuator or valve if the valve binds in an intermediate position.

Summary

The important information in this chapter is summarized below.

Valve Actuator Summary

- Pneumatic actuators utilize combined air and spring forces for quick accurate responses for almost any size valve with valve position ranging from 0-100%.
- Hydraulic actuators use fluid displacement to move a piston in a cylinder positioning the valve as needed for 0-100% fluid flow. This type actuator is incorporated when a large amount of force is necessary to operate the valve.
- Solenoid actuators are used on small valves and employ an electromagnet to move the stem which allows the valve to either be fully open or fully closed.
- Equipped with limit switches and/or torque limiters, the electric motor actuator has the capability of 0-100% control and has not only a motor but also a manual handwheel, and a clutch and gearbox assembly.

end of text.

CONCLUDING MATERIAL

Review activities:

DOE - ANL-W, BNL, EG&G Idaho,
EG&G Mound, EG&G Rocky Flats,
LLNL, LANL, MMES, ORAU, REEC_o,
WHC, WINCO, WEMCO, and WSRC.

Preparing activity:

DOE - NE-73
Project Number 6910-0019/2